

AMIDD 2024 Lecture 10: Pharmacokinetic and Pharmacodynamic Modelling

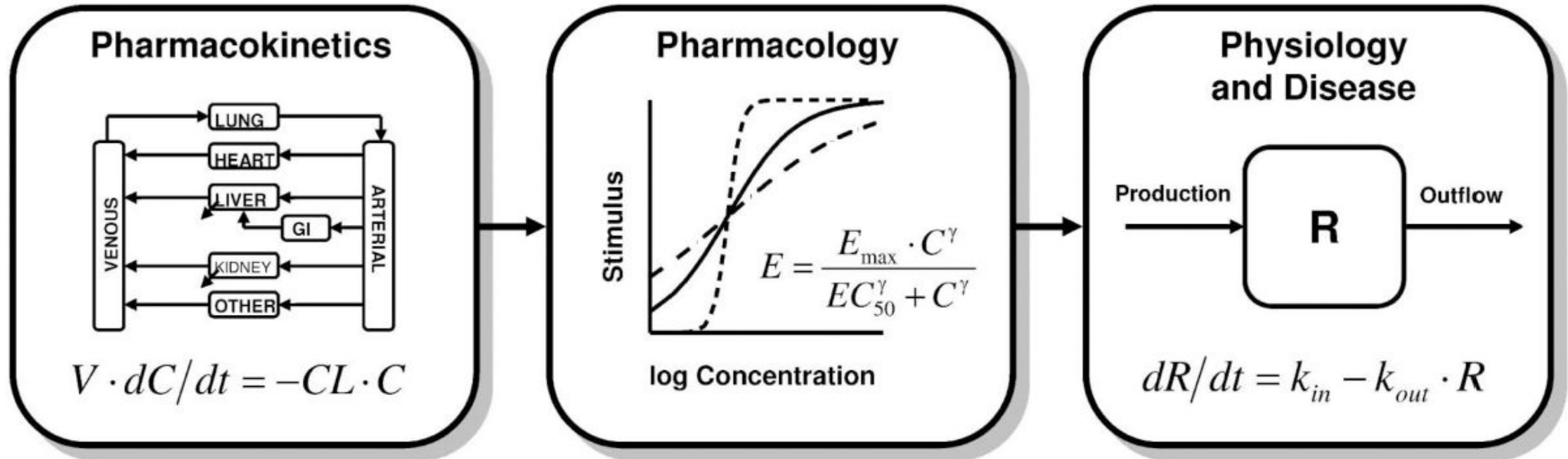

Mager, Donald E., Sukyung Woo, and William J. Jusko. 2009. "Scaling Pharmacodynamics from In Vitro and Preclinical Animal Studies to Humans." *Drug Metabolism and Pharmacokinetics* 24 (1): 16–24.

Dr. Jitao David Zhang, Computational Biologist

¹ *Pharmaceutical Sciences, Pharma Research and Early Development, Roche Innovation Center Basel, F. Hoffmann-La Roche*

² *Department of Mathematics and Informatics, University of Basel*

Topics

- **Pharmacokinetic (PK) modelling**
- **Pharmacokinetic-pharmacodynamic (PK-PD) modelling**
- **Basics of clinical trials**

Key questions to solve in preclinical development: how much and how often can we give the drug?

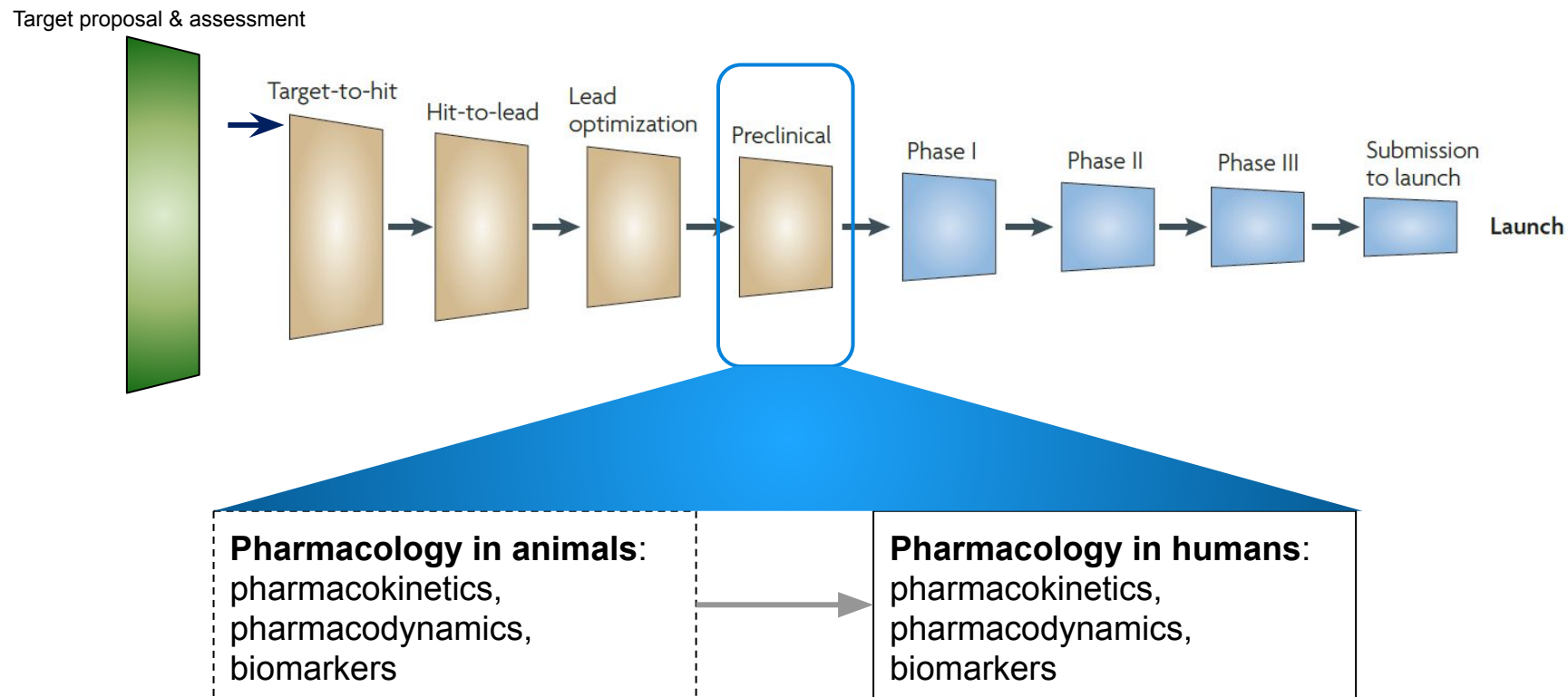

Adapted from Paul *et al.* "How to Improve R&D Productivity: The Pharmaceutical Industry's Grand Challenge." *Nature Reviews Drug Discovery*, 2010

Pharmacokinetic and pharmacodynamic modelling

- Pharmacokinetics (PK) describes how the drug is absorbed, distributed, metabolised, and excreted by the body (ADME).
 - The ADME properties are affected by physicochemical properties of the drug, patient’s genetics make-up, and other factors such as human behavior (e.g. food and drug intake).
- Pharmacodynamics (PD) describes the effect of the drug to the body, mediated by drug-target interactions. PD is affected by PK, as well as other properties such as behaviour and genetics.

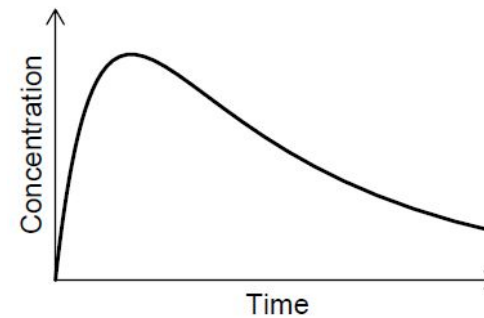
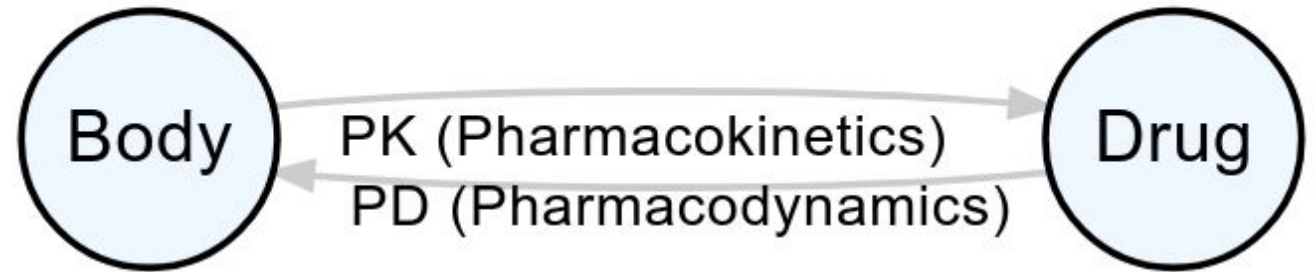

(a) PK model

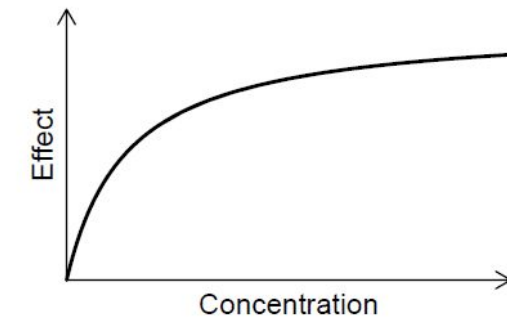

(b) PD model

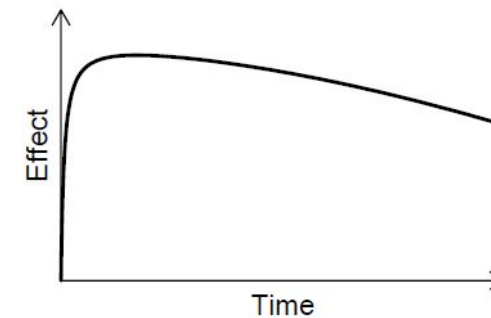

(c) Combined PK/PD model

Mortensen, Stig Bousgaard, Anna Helga Jónsdóttir, Søren Klim, and Henrik Madsen. 2008. "Introduction to PK/PD Modelling - with Focus on PK and Stochastic Differential Equations." Technical University of Denmark, DTU Informatics.

Modelling pharmacokinetics with ADME properties

- ADME properties determine how much drug is found where at which time point.
- The ADME properties, together with the pharmacodynamics and off-target effects of the drug, determine the efficacy and safety profiles of a drug.

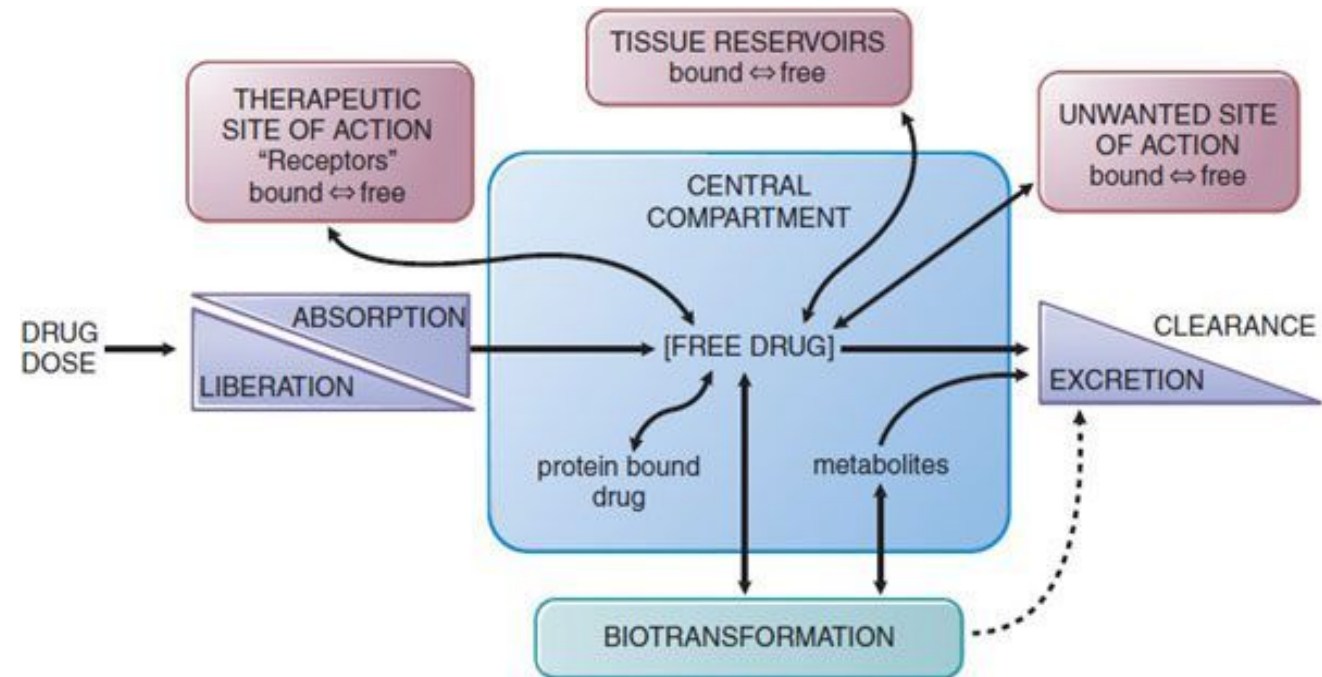

Pharmacokinetics: The Dynamics of Drug Absorption, Distribution, Metabolism, and Elimination

Principles of absorption, release of the active compound

Process by which a drug compound transfers from an extravascular site of dosing (e.g. gut, lung, muscle, and skin) into systemic circulation, known as the **central compartment**.

- Intravenous administration in a *bolus* dose (single dose, short time) is often modelled as instant absorption. Infusion using a constant rate over time can be modelled as instant absorption by time.
- Extravascular administration, for instance (a) oral or (b) injection into muscle or fat tissue, needs to be absorbed. During this process the drug concentration may reduce due to metabolism and trapping. The ratio between active drug concentration reaching the central compartment and the in-take concentration is known as the **bioavailability**.

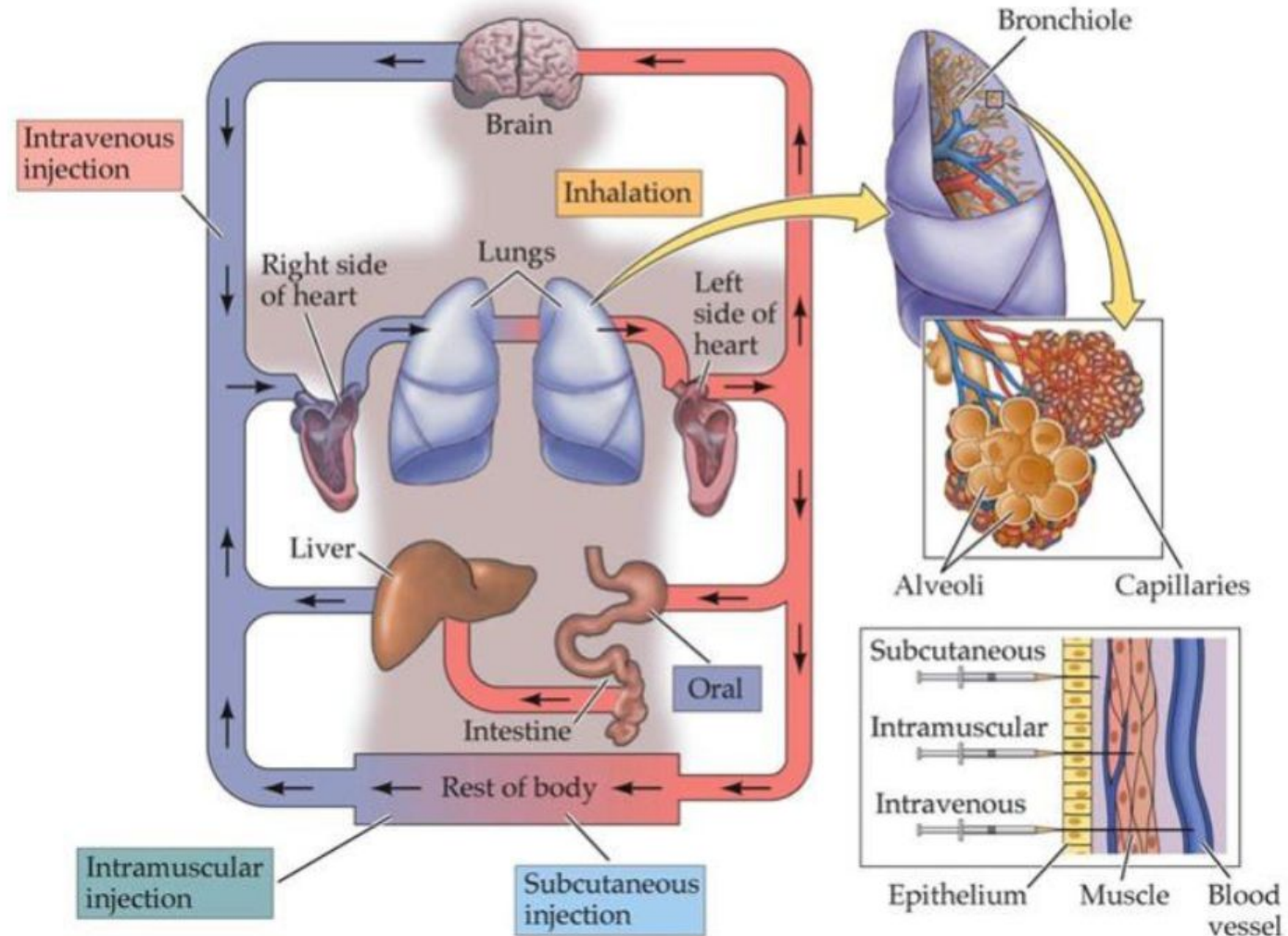

Psychopharmacology, Figure 1.2

Principles of distribution

- Following absorption, drug molecules are distributed into organs and tissues. Different organs receive different drug doses and have different concentration-time relationships.
- Distribution of a drug in a tissue is determined by both **physicochemical properties of the drug**, e.g. plasma protein binding, and lipophilicity, and **physiological factors**, e.g. the vascular permeability, blood flow, the perfusion rate of the tissue.
 - Liver and kidney are better perfused than muscle and fat, and brain is usually inaccessible due to the blood-brain barrier.
 - Only free compounds that are not bound to plasma proteins can exert pharmacological functions. Protein binding delays drug distribution.

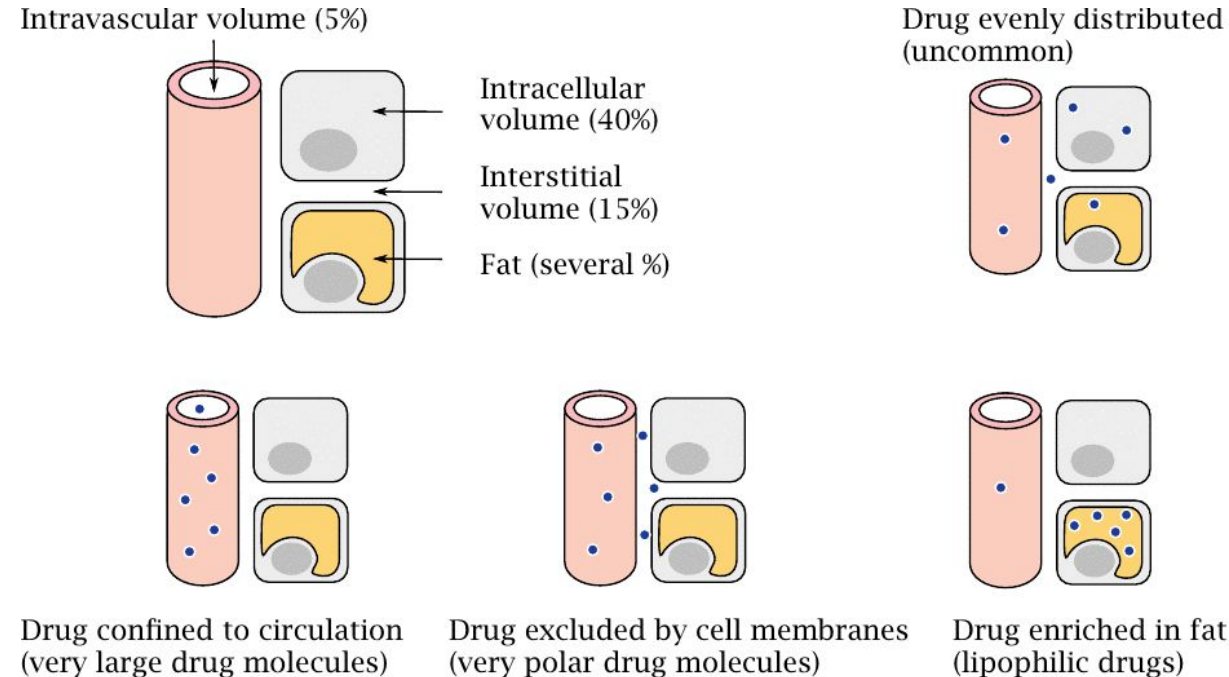

Major components of drug distribution, [U Waterloo](#)

We use the Volume of distribution, V_D , to describe the extent of distribution. The larger the value is, the better the distribution to tissues. A value larger than human circulation volume (0.08 l/kg) is possible.

$$V_D = \frac{\text{total amount of drug in the body}}{\text{drug blood plasma concentration}}$$

Principles of metabolism

- Drug metabolism happens mainly in liver and, for oral drugs, in intestine
- Drug metabolism serves defense against xenobiotics. It facilitates the excretion of the drug by making it hydrophilic.
- Drug metabolism can deactivate a compound (very often the case) or activate a compound, turning a **pro-drug** into its active form, e.g. codeine to morphine, top).
- Drug metabolism varies between individuals, between ages in the same individual, and can be affected by drugs as well. Drugs that induce or repress drug-metabolism genes (e.g. cytochrome P450, CYPs) can cause **drug-drug interaction** (DDI; below: an *in vitro* DDI assay for the drug Irinotecan).

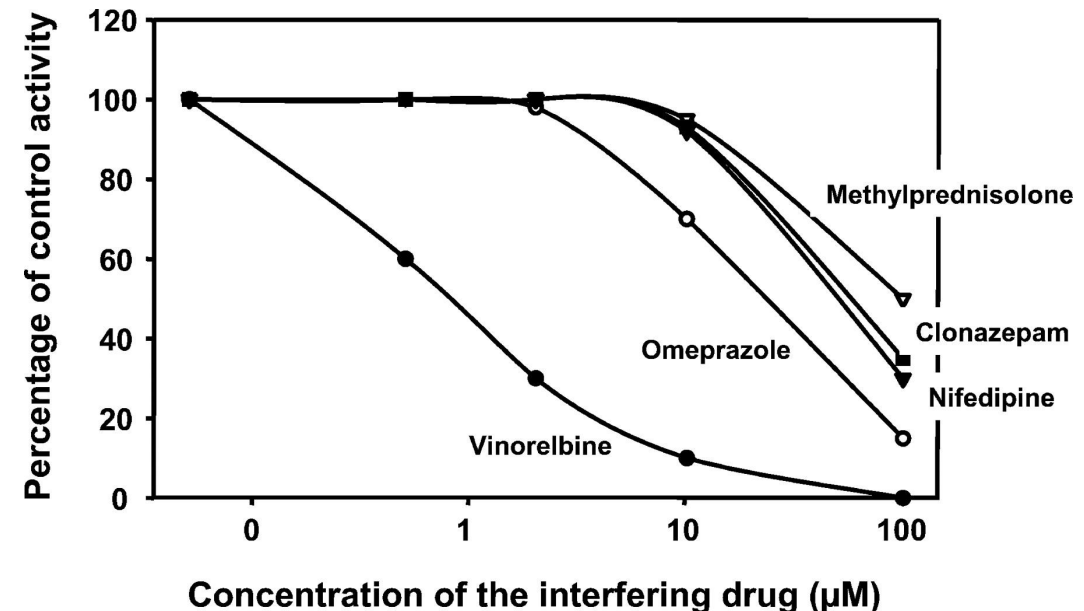
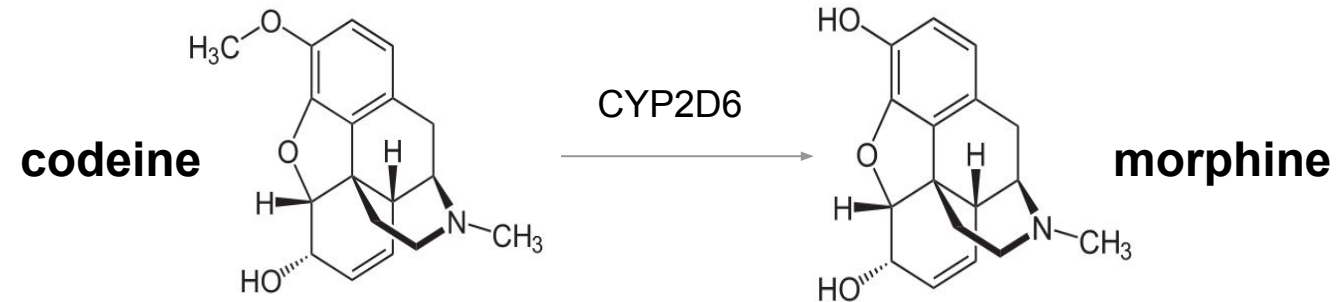

Charasson, V., Haaz, M.-C. & Robert, J. Determination of Drug Interactions Occurring with the Metabolic Pathways of Irinotecan. Drug Metab Dispos 30, 731-733 (2002).

Principles of excretion, which contributes together with metabolism to *clearance*

- Excretion removes drugs and their metabolites from the body.
- The main excretion route is the **urinary** and **biliary** (thereby with feces) **excretion**.
 - Urinary excretion include three components: glomerular filtration, secretion, and reabsorption.
 - Patients with kidney diseases may have reduced excretion, calling for adjusted dosing.

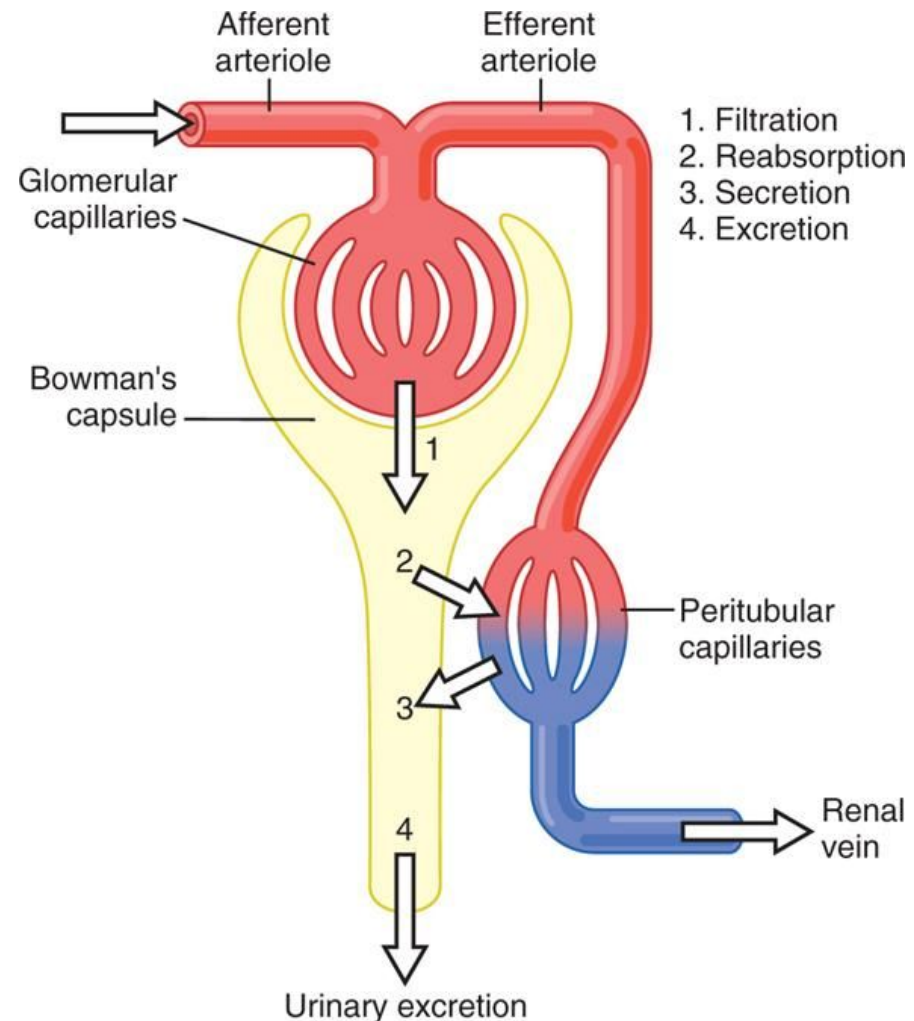

Pharmacokinetics properties

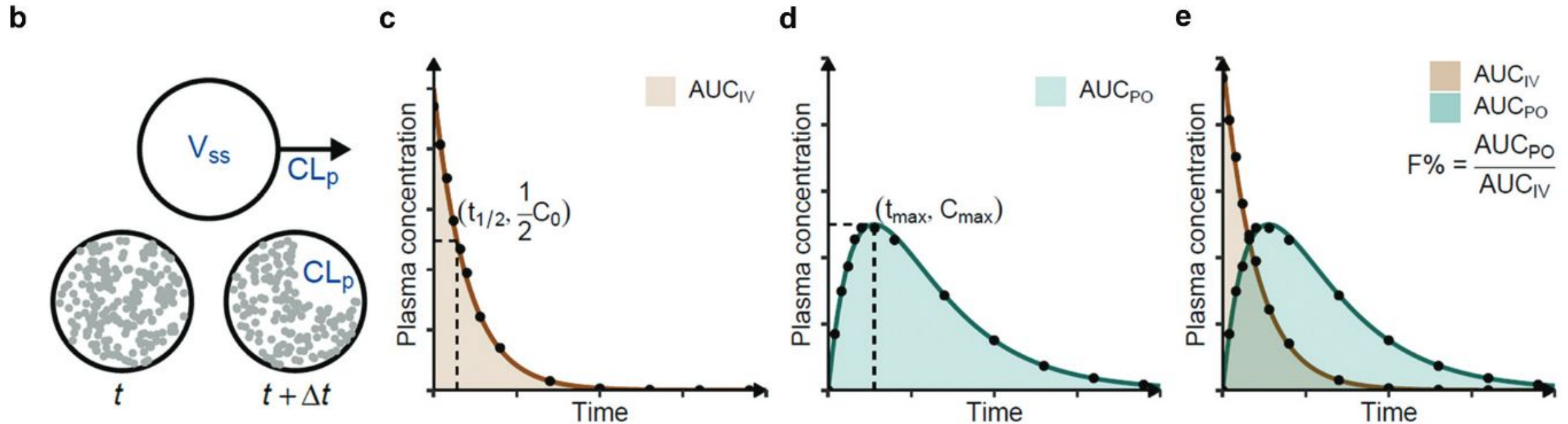

PK properties in human can be predicted by

- *In-vitro-in-vivo* extrapolation (IVIVE) based on *in vitro* systems.
- Physiological-based pharmacokinetic (PBPK) modelling based on *in vitro* and *in vivo* results.
- Machine-learning models based on *in vitro* and *in vivo* results.

Mathematical modelling of PK: one-compartment model, bolus

We denote the concentration of the drug as A , and the rate of clearance (metabolism and excretion) as K . Assuming a bolus dose, according to the law of mass action and first-order kinetics, we can write

$$\frac{dA}{dt} = -K \cdot A$$

When we denote the initial dose as A_0 , we can express the general solution of the model as

$$A_{bolus}(t) = A_0 \exp(-K \cdot t)$$

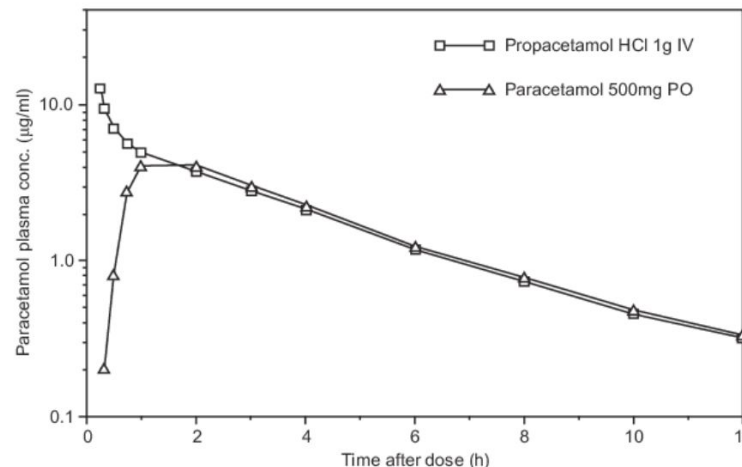
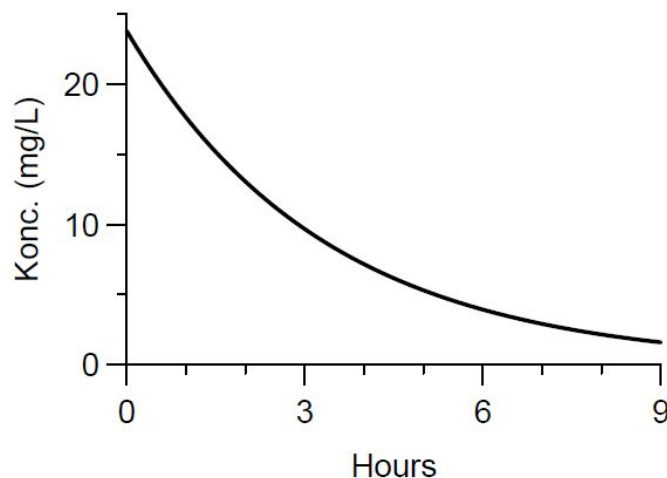
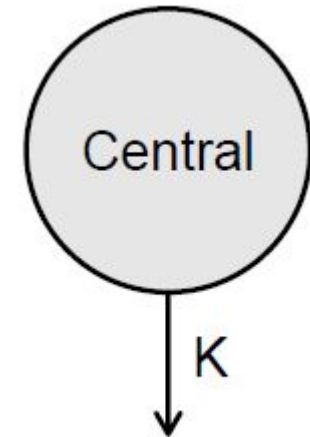

(Left) simulation from *Introduction to PK/PD Modelling - with Focus on PK and Stochastic Differential Equations* (Right) empirical data of propacetamol HCl (IV, intravenous) and paracetamol (PO, *per os*, oral).

Propacetamol is a pro-drug of paracetamol. The chemical modification (esterification) makes it more water soluble, allowing it delivered via IV.

Question: what is the half-life of the drug, $t_{1/2}$, the time it takes for reducing the amount of drug left in the body by 50%?

One-compartment model, oral dosing

For oral dosing, an extra gut compartment (right) is often sufficient to model the absorption phase

$$\frac{dA_{gut}}{dt} = -K_a \cdot A_{gut}$$

Suppose rate the absorption of the drug is faster than the elimination process ($K_a > K$), we can model the concentration in the central compartment as

$$\frac{dA}{dt} = \overbrace{F \cdot K_a \cdot A_{gut}}^{\text{from gut}} - \overbrace{K \cdot A}^{\text{elimination}}$$

In reality, we cannot easily assess the concentration of drug in the gut. Is it possible to derive the relationship between central-compartment concentration A and time t given the initial condition?

Yes: we can find the expression of $A(t)$ analytically in a closed form using *Laplace transform*, which translates a function of a continuous variable (e.g. time) to a function of a complex variable (frequency) (see backup).

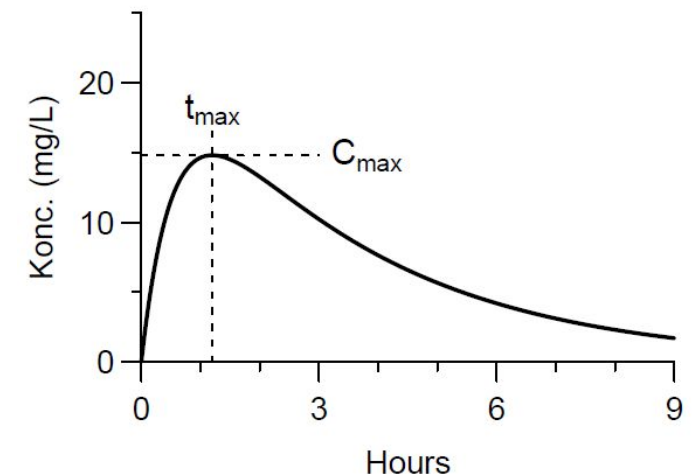
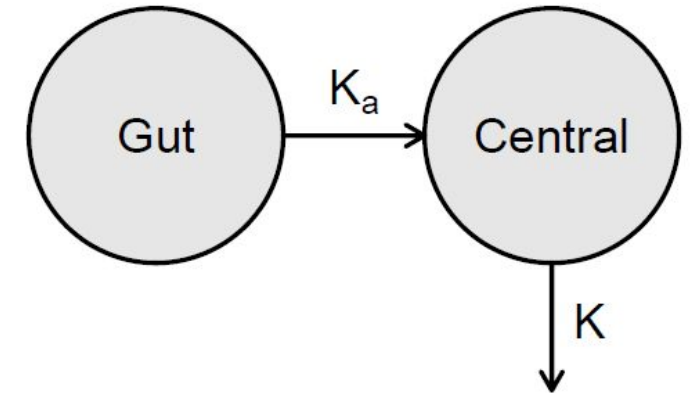

Solving the two-equation system with the Laplace transform

System: Letting $A_a(t)$ be the amount of drug at the absorption site at time t

$$\begin{aligned} \dot{A}(t) &= k_a A_a(t) - k_e A(t) \\ \dot{A}_a(t) &= -k_a A_a(t) \end{aligned}$$

with initial conditions $A_a(0) = A_{a0} = FD$, $A(0) = A_0 = 0$, where F is the fraction available (take $F \equiv 1$ for simplicity)

Marie Davidian, MA/ST 810, *Mathematical-Statistical Modeling and Analysis of Complex Systems*, NC State University.

A table of Laplace transforms can be found on intmath.com

Laplace transform of $A(t)$: $\mathcal{L} A = \int_0^\infty e^{-st} A(t) dt$

$$s\mathcal{L} A - A_0 = k_a \mathcal{L} A_a - k_e \mathcal{L} A \tag{1}$$

$$s\mathcal{L} A_a - A_{a0} = -k_a \mathcal{L} A_a \tag{2}$$

- Solve (2) for $\mathcal{L} X_a$ and substitute in (1) to obtain

$$\mathcal{L} A = \frac{k_a FD}{(s + k_e)(s + k_a)}$$

- From a table of Laplace transforms, we find immediately that

$$A(t) = \frac{k_a FD}{k_a - k_e} \{e^{-k_e t} - e^{-k_a t}\}$$

so that (divide by V)

$$C(t) = \frac{k_a FD}{V(k_a - k_e)} \{e^{-k_e t} - e^{-k_a t}\}$$

See more about the Laplace transform and other numeric transforms in Bracewell, R. N. 1990. "[Numerical Transforms.](#)" *Science* 248 (4956): 697–704.

One-compartment model, oral (or extravascular) dosing

$$A_{oral}(t) = \frac{K_a F A_0}{K_a - K} (\exp(-K \cdot t) - \exp(-K_a \cdot t))$$

replacing amount with concentration

$$C_{oral}(t) = \frac{A_{oral}(t)}{V} = \frac{K_a F A_0}{V(K_a - K)} (\exp(-K \cdot t) - \exp(-K_a \cdot t))$$

solving by differentiation

$$t_{max} = \frac{1}{K_a - K} \ln \left(\frac{K_a}{K} \right)$$

replacing t with t_{max}

$$C_{max,oral} = \frac{K_a F A_0}{V(K_a - K)} (\exp(-K \cdot t_{max}) - \exp(-K_a \cdot t_{max}))$$

simplification

$$C_{max,oral} = \frac{F A_0}{V} \exp(-K \cdot t_{max})$$

- The parameter t_{max} describes the time to reach the maximum plasma concentration of the drug since dosing.
- The parameter C_{max} describes the maximum plasma concentration of the drug.

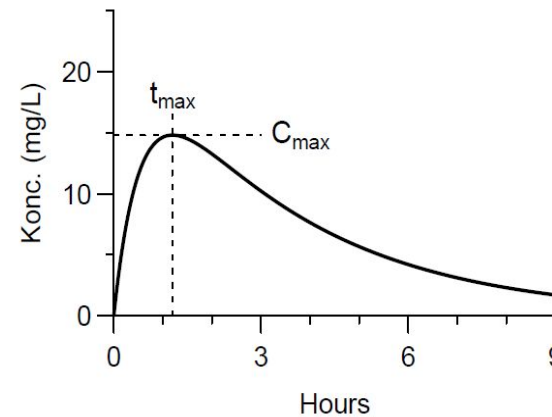
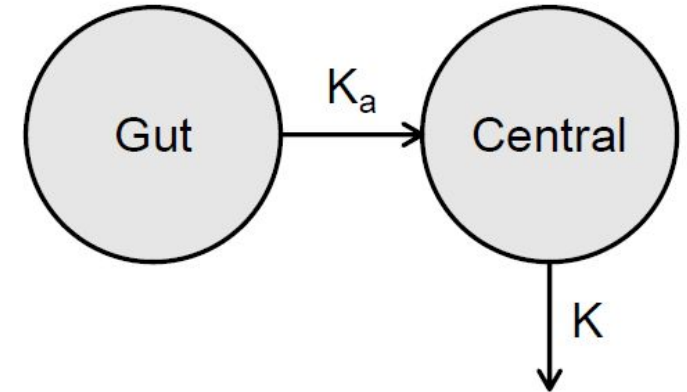

Simulated PK profile of 1000mg paracetamol (PO)

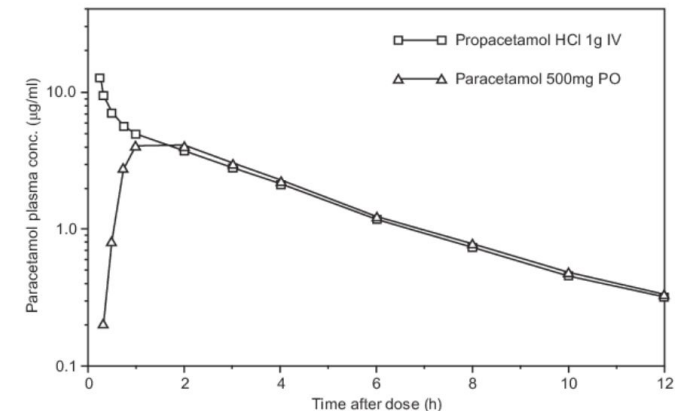

Empirical PK profile of 1000mg paracetamol (PO)

Physiologically based pharmacokinetic (PBPK) models

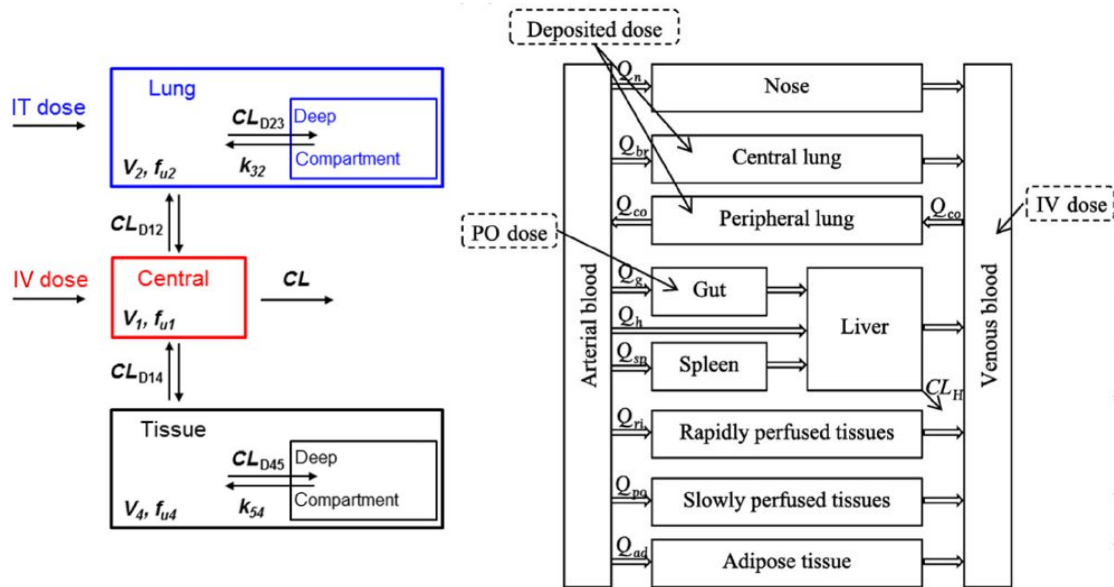

(Left) A semi-physiological model (Right) A fully physiology-based PK model

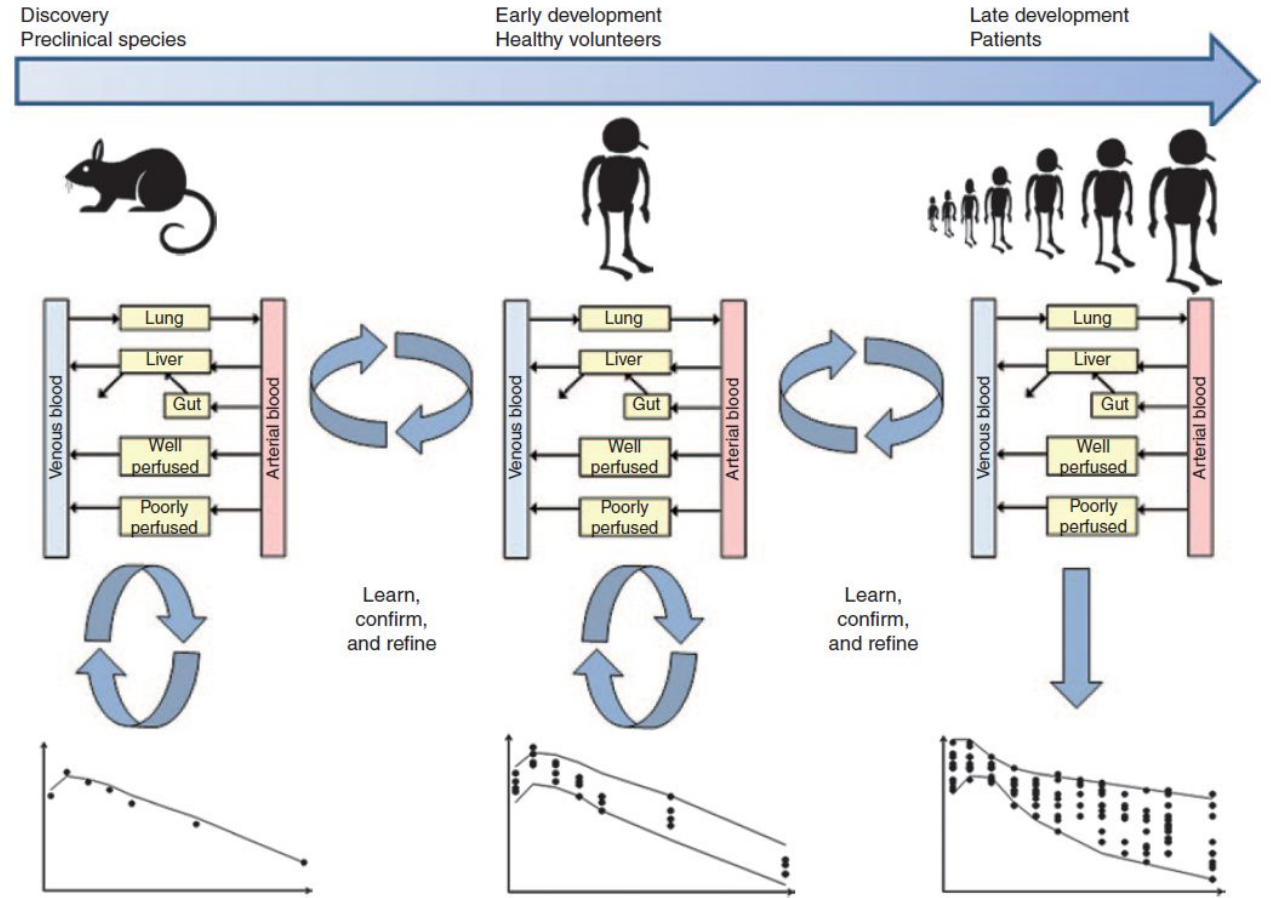

PBPK is usually performed in an iterative “learn, confirm, and refine” approach between in vivo, smaller number of human volunteers, and larger populations.

Right figure: Jones, H. M., and K. Rowland-Yeo. 2013. “[Basic Concepts in Physiologically Based Pharmacokinetic Modeling in Drug Discovery and Development.](#)” CPT: Pharmacometrics & Systems Pharmacology 2 (8): 63.

Besides PBPK, we can use machine-learning models based on *in vitro* and *in vivo* data to predict PK parameters

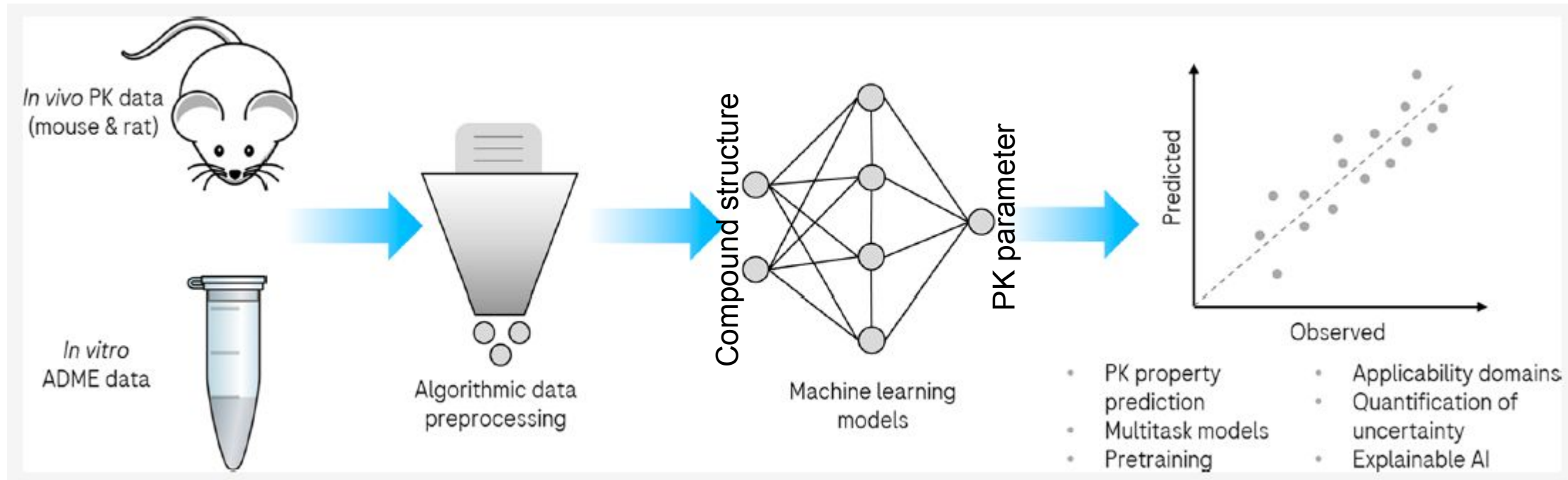

Stoyanova, R. et al. Computational Predictions of Nonclinical Pharmacokinetics at the Drug Design Stage. *J. Chem. Inf. Model.* 63, 442–458 (2023).

Constant-rate infusion and multiple dosing

We can administer the drug with infusion over time. If we assume a constant infusion amount R_{in} and a constant clearance constant CL , we can derive the analytical solution of drug concentration with regard to time.

- **Question:** what form does it have?

If a pill releases its active ingredient gradually, the plasma concentration is comparable to a constant-rate infusion. If pills are taken with time intervals, the constant R_{in} can be expressed as a product of bioavailability F and initial dose A_0 , divided by the time interval of taking pills τ . The concentration of **multiple dosing (MD)** can be expressed as the sum of individual dosing profiles (N : number of doses)

The system reaches equilibrium when the infusion rate equals the clearance rate ($dC/dt=0$). Therefore we can deduce the concentration at steady state C_{SS} by the ratio of infusion rate and clearance. Due to the exponential distribution, 90% of the the steady-state concentration is reached after 3-4 half-lives.

$$\frac{dC}{dt} = \frac{R_{in}}{V} - \frac{CL}{V} \cdot C$$

$$C(t) = \frac{R_{in}}{CL} \left[1 - \exp\left(-\frac{CL}{V}t\right) \right]$$

$$R_{in} = \frac{F \cdot A_0}{\tau}$$

$$C_{MD}(t) = \sum_{n=0}^{N-1} C_{oral}(t - n\tau)$$

$$\frac{R_{in}}{V} = \frac{CL}{V} C_{SS}$$

$$C_{SS} = \frac{R_{in}}{CL}$$

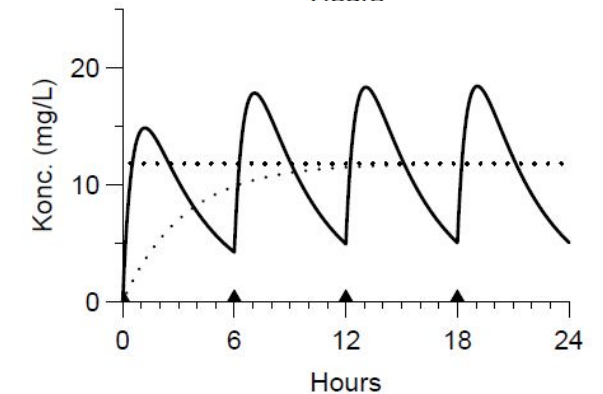
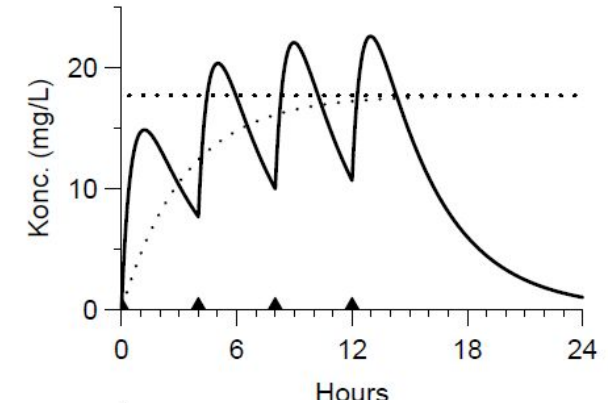

Multiple dosing of paracetamol, with 4 oral doses of 1g per dose given at two different intervals (top: 4h, bottom: 6h). Thick line: total concentration. Dotted line: the rate of constant infusion.

Multi-dosing PK studies mimic most real-world scenarios

- The PK profile determines
 - dose (how much)
 - dosing regimen (how often and for how long)
 - dosage form (which formulation)
 - dosage route (systemic? local?)
- The **therapeutic window** (from the view of PK) or the **therapeutic index** (from the view of PD) determines how much and often a drug is dosed.
- A narrow therapeutic index may lead to project termination, or additional requests from the regulatory authority in preclinical development or additional labelling in drug product.

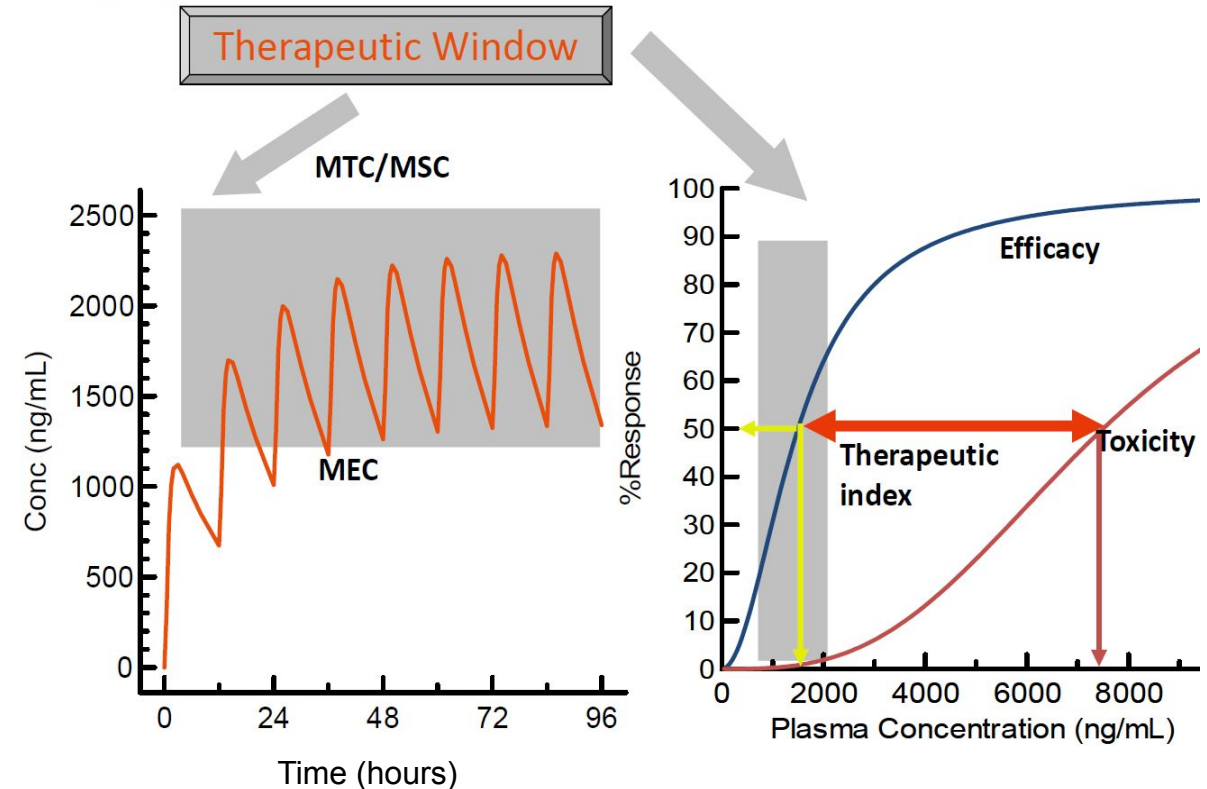

Courtesy of Jun Shi. MEC: minimal effect concentration; MTC/MSC: minimum toxic concentration/maximum safe concentration

Two-compartment model

A piecewise linear relationship between logarithm-transformed concentration and time often indicates that one-compartment model is not sufficient. Multi-compartment models can be used in these cases.

Similar to one-compartment model, we can set up two differential equations describing the compartment model. The solution has the general form of a weighted sum of two exponentially distributed variables.

The propacetamol data that we seen before may be modelled by a two-compartment model.

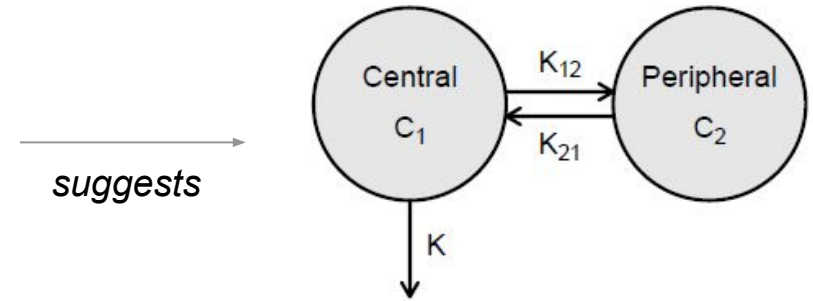
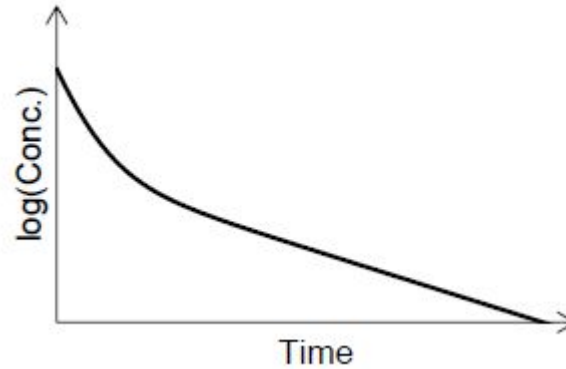

$$\begin{aligned} \frac{dC_1}{dt} &= K_{21} \cdot C_2 - K_{12} \cdot C_1 - K \cdot C_1 \\ \frac{dC_2}{dt} &= K_{12} \cdot C_1 - K_{21} \cdot C_2 \end{aligned}$$

$$C = A \cdot \exp(-\alpha t) + B \cdot \exp(-\beta t)$$

solution

$$t_{1/2,\alpha} = \frac{\log(2)}{\alpha} \quad t_{1/2,\beta} = \frac{\log(2)}{\beta}$$

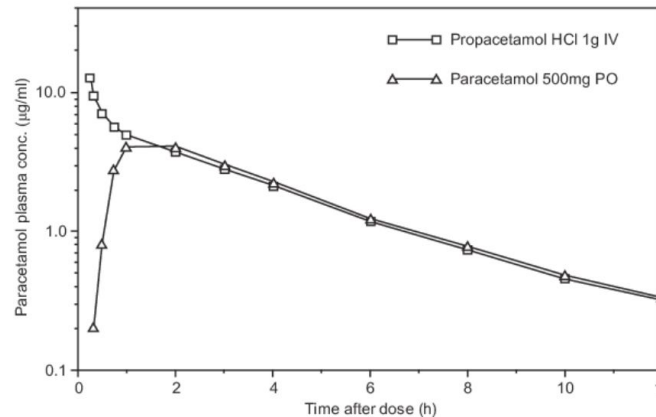

The simplest joint PK/PD model: a binary PD model with a step function

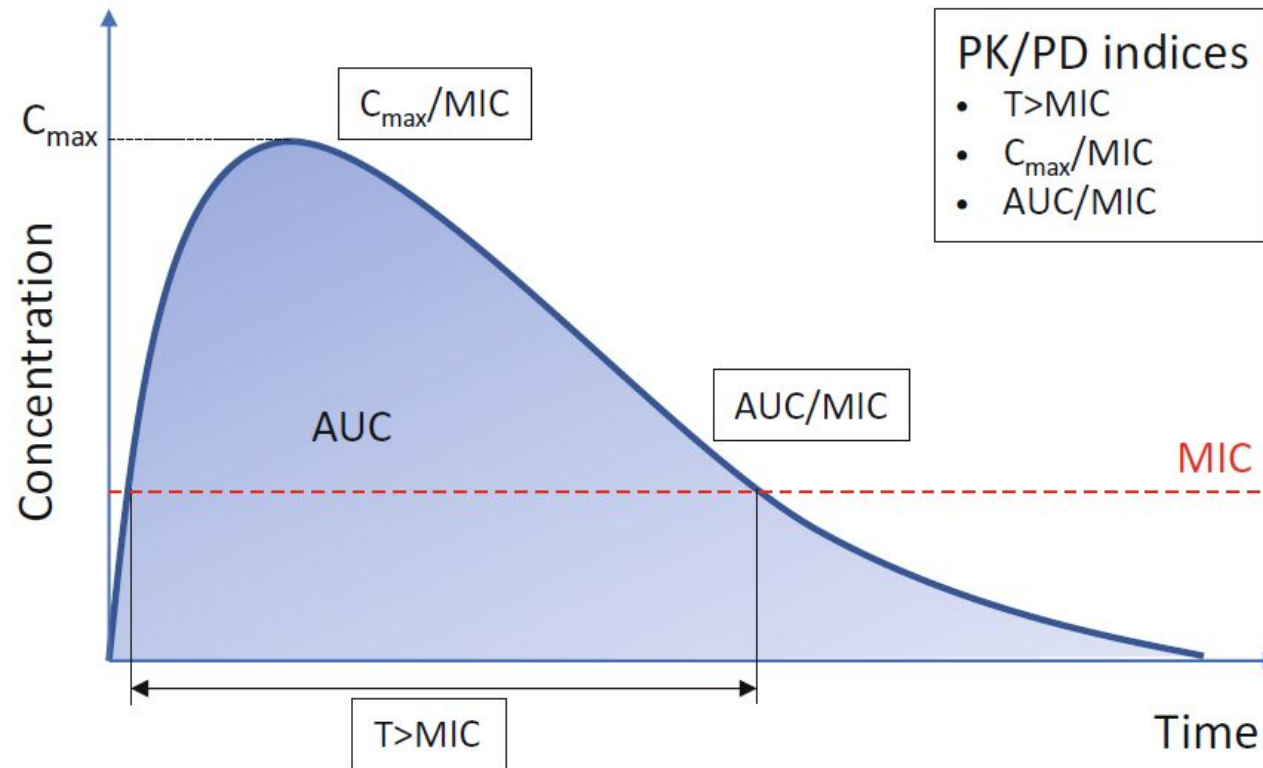

Pharmacokinetic-pharmacodynamic indices of a theoretical drug molecule. MIC: Minimum inhibitory concentration (MIC).

Yu, Yichao, Diether Ruppel, Willi Weber, and Hartmut Derendorf. 2018. "[PK/PD Approaches.](#)" In Drug Discovery and Evaluation: Methods in Clinical Pharmacology.

An example of joint PK/PD model: oral dosing of paracetamol

- PD models have many forms. The example is taken from Mortensen *et al.* and Gibb and Anderson (2008). It uses a hypothetical effect compartment with an E_{max} model (the Hill function that we introduced before) to model the effect. It does not influence of the PK model.
- The effect is measured on a visual analogue scale (VAS) from 0-10 where a reduction indicates pain relief.

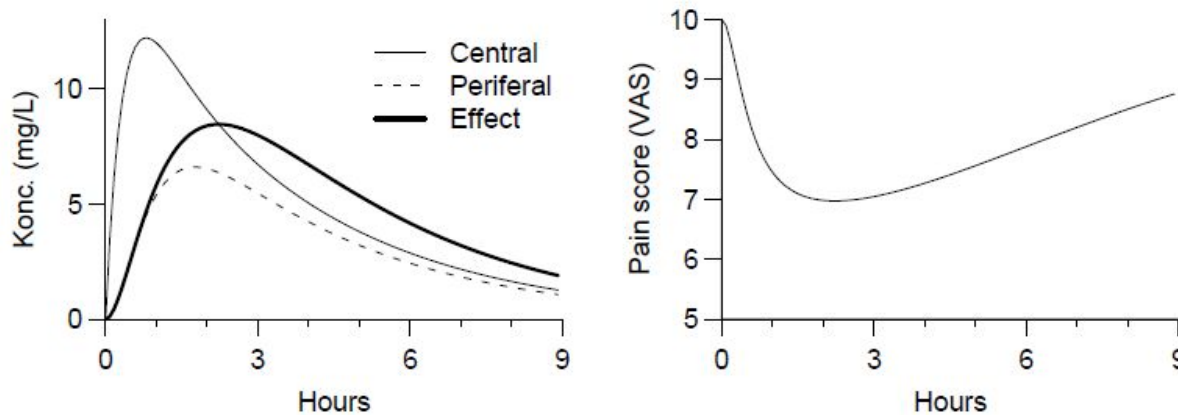
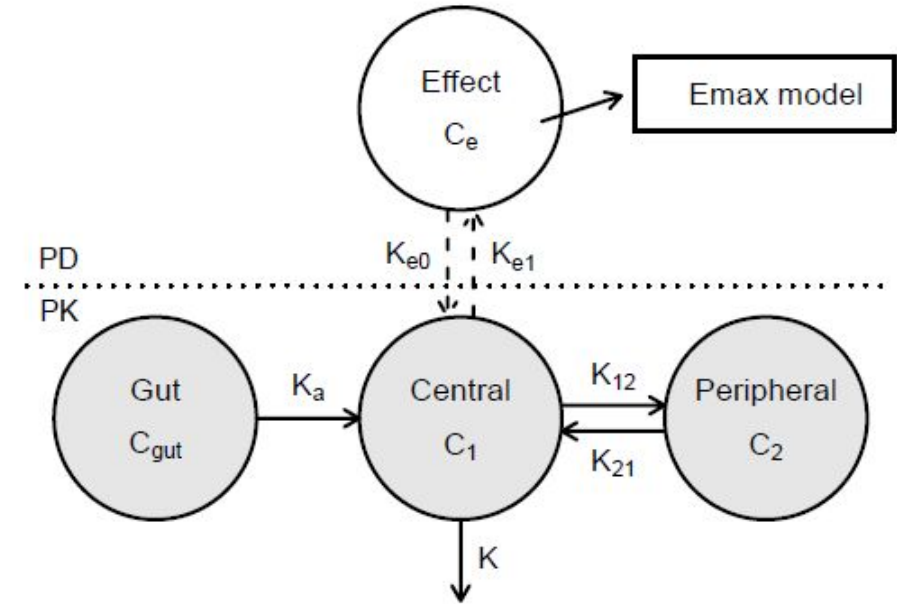

PK model

$$\begin{aligned} dC_{gut}/dt &= -K_a C_{gut} \\ dC_1/dt &= -k_{12}C_1 + k_{21}C_2 - k_{10}C_1 + FK_a C_{gut} \\ dC_2/dt &= k_{12}C_1 - k_{21}C_2 \end{aligned}$$

Effect compartment

$$dC_e/dt = k_{e1}C_1 - k_{e0}C_e$$

PD model

$$\text{Effect} = 10 - \frac{E_{max}C_e}{EC_{50} + C_e}$$

An industrial PK modelling workflow by AstraZeneca

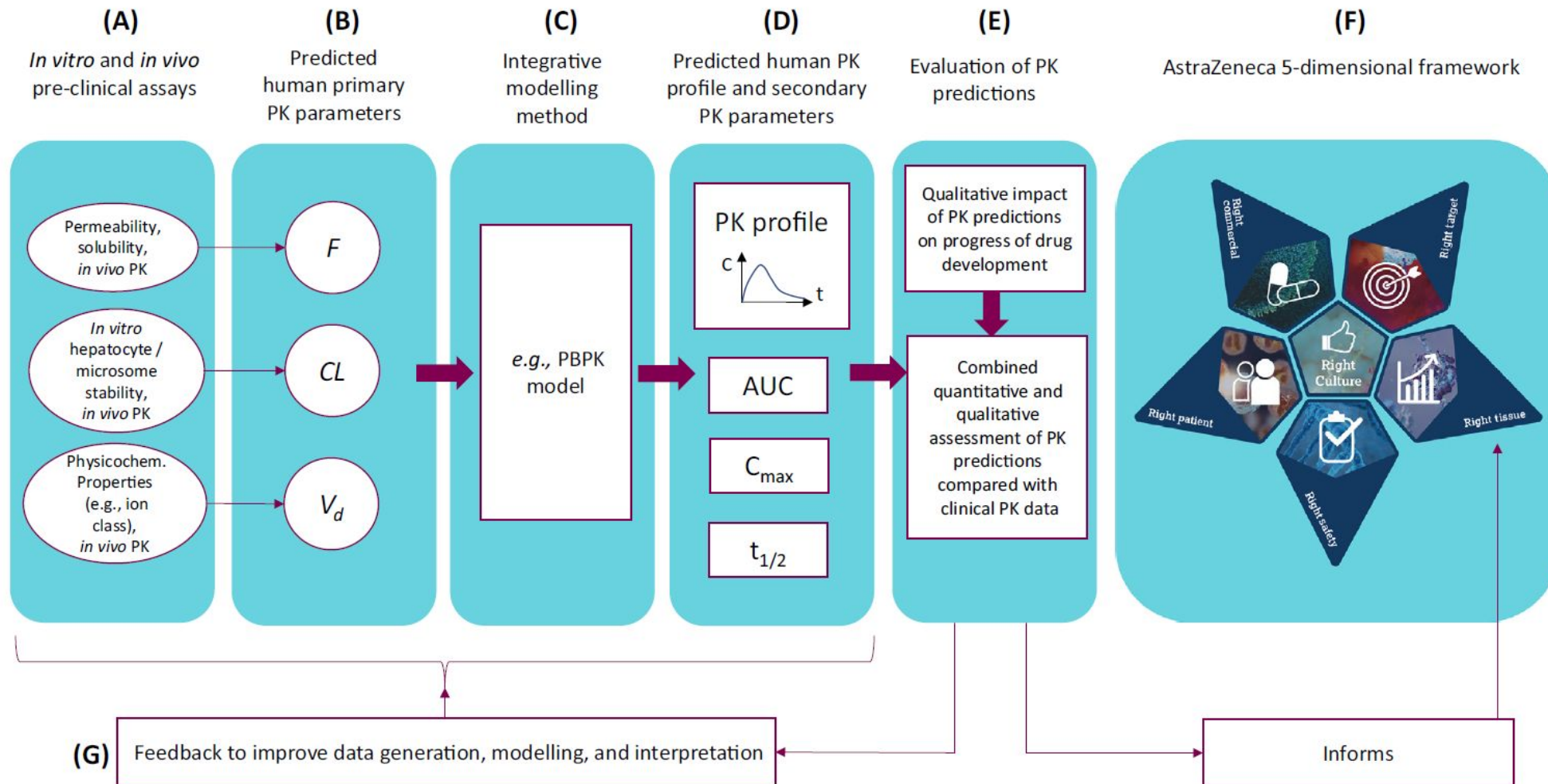

Davies, Michael, *et al.*. 2020. [“Improving the Accuracy of Predicted Human Pharmacokinetics: Lessons Learned from the AstraZeneca Drug Pipeline Over Two Decades.”](#) Trends in Pharmacological Sciences 41 (6): 390–408.

Summary

Pharmacokinetics: what the body does to the drug

- Determined by ADME properties
- Determines dosing regimen, form, dosage route
- Important parameter include clearance (CL), volume of distribution (V_D), and bioavailability (F).

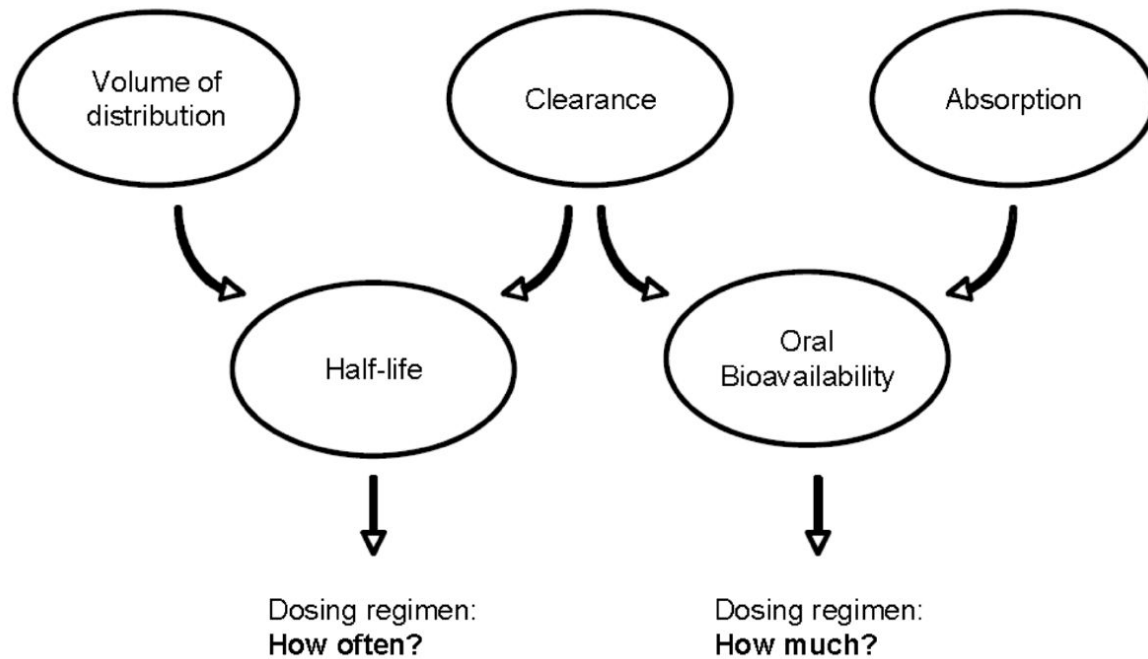

Pharmacodynamics: what the drug does to the body

- Determined by drug-target and off-targets interactions
- Determines efficacy and safety profiles
- Can be modelled in many different ways, for instance the Hill function.

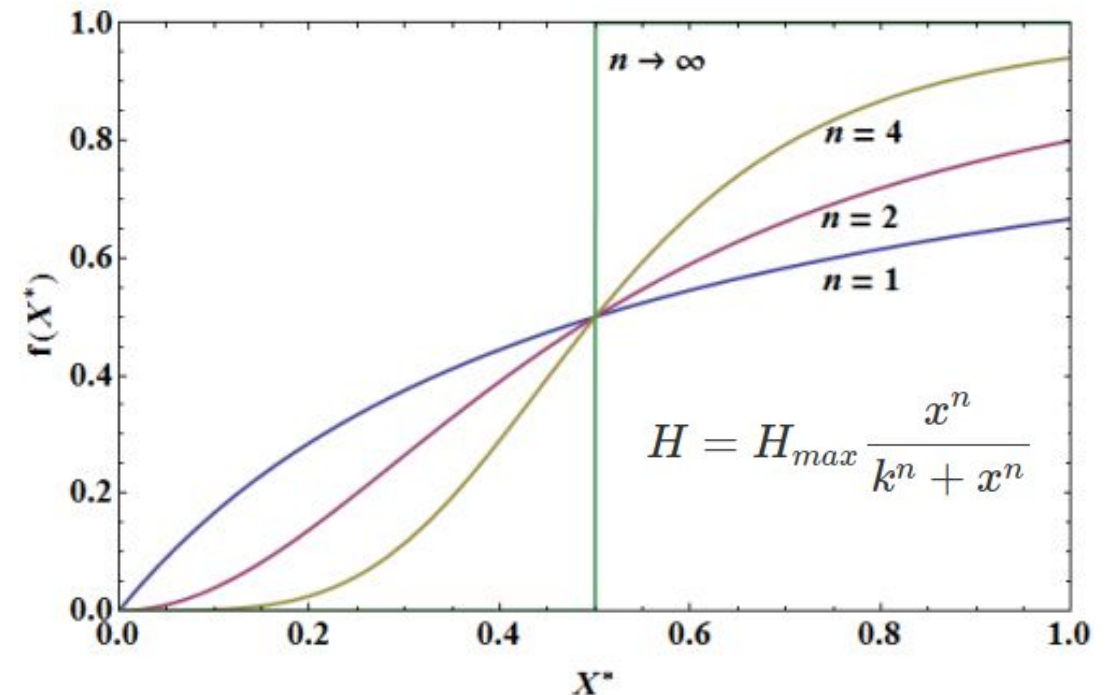

From [the biophysics wiki article](#) by Andreas Piehler

Phases of clinical trials prior to approval

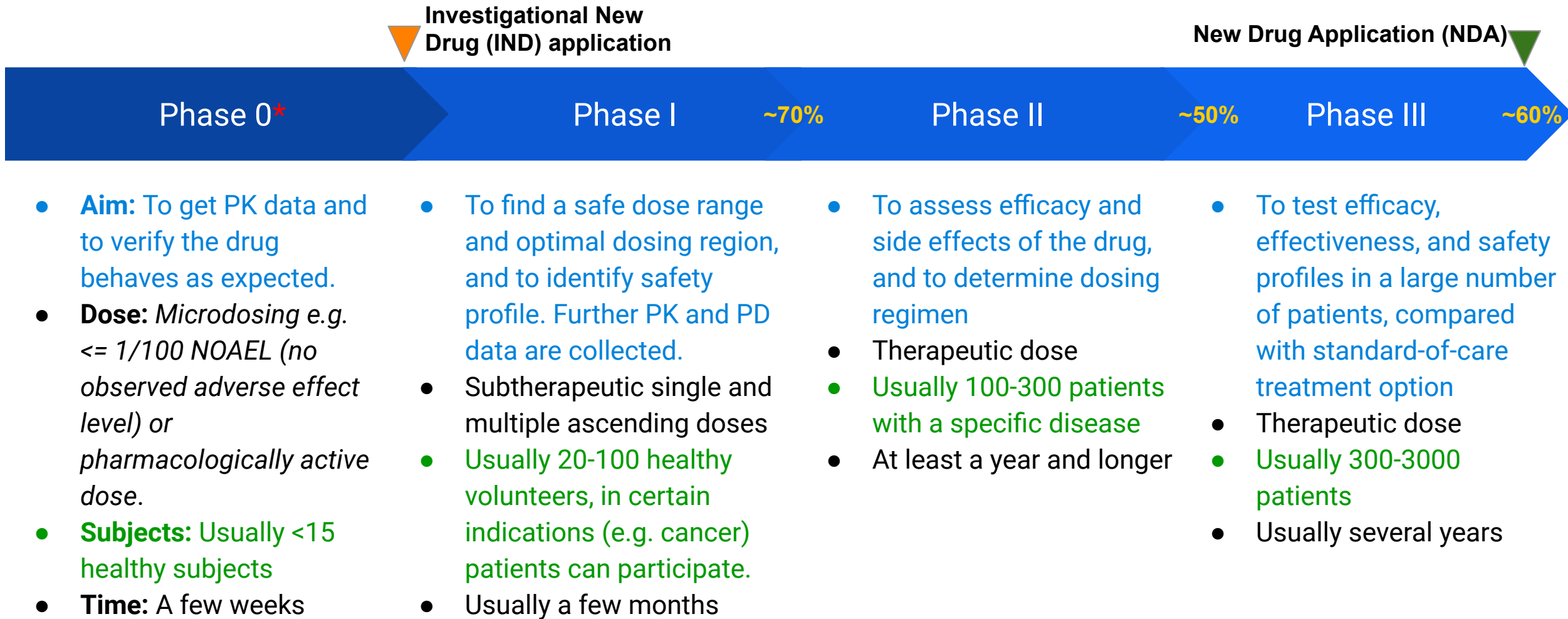

* Since early 2000. See an update-to-date review by Burt, Tal, Graeme Young, Woojin Lee, Hiroyuki Kusuhara, Oliver Langer, Malcolm Rowland, and Yuichi Sugiyama. 2020. "[Phase 0/Microdosing Approaches: Time for Mainstream Application in Drug Development?](#)" Nature Reviews Drug Discovery 19 (11): 801–18.

Offline activities

Required readings: pick *one* publication to read, depending on your interest

- a. [Introduction to PBPK modelling] Jones, H. M., and K. Rowland-Yeo. 2013. “Basic Concepts in Physiologically Based Pharmacokinetic Modeling in Drug Discovery and Development.” CPT: Pharmacometrics & Systems Pharmacology 2 (8): 63. <https://doi.org/10.1038/psp.2013.41>.
- b. [Application of machine learning for PK prediction] Stoyanova, R. et al. [Computational Predictions of Nonclinical Pharmacokinetics at the Drug Design Stage](#). J. Chem. Inf. Model. 63, 442–458 (2023).

Conclusion of the course

Multiscale Modelling of Drug Mechanism and Safety

Forward translation

CCAUCAUAAGGAAGAAGCCC
GGTAGTTATTCCTTCTTCGGG

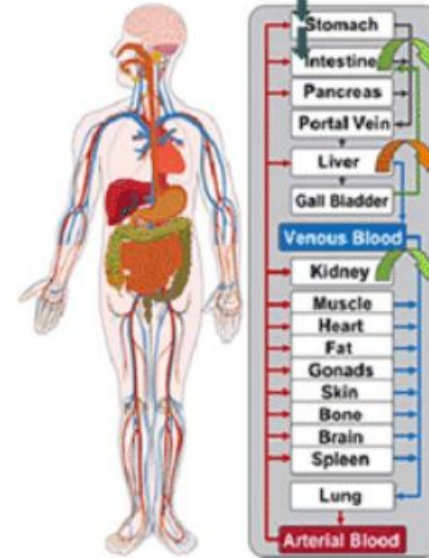
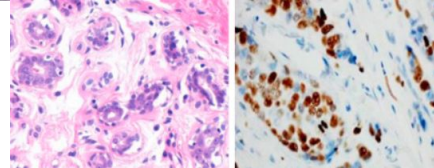
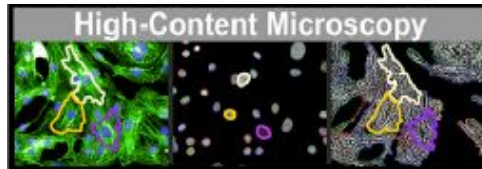
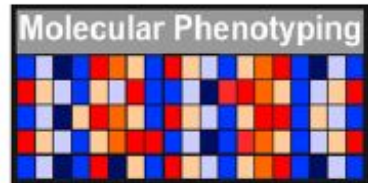
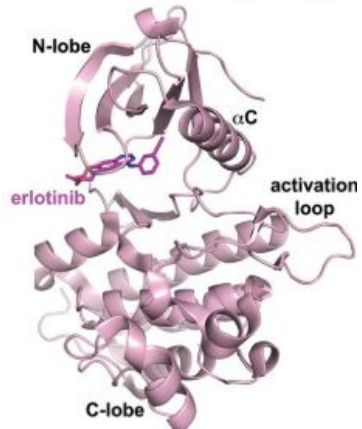

Molecular modelling

Omics & cellular modelling

Organ & system modelling

Populational modelling

Reverse translation

Principles that we covered: molecular biology (the central dogma), bioinformatics (DP and MC/HMM), chemoinformatics and CADD (molecular descriptors, QSAR, docking), omics (RNA sequencing), pharmacology (PK, PD, PBPK), ...

Thank you for...

- Attending the course and working diligently
- Hopping between disciplines and constantly learning about new things
- Asking great questions, and giving me and the course feedback

Hopefully see you in MCBDD 2025!

Mathematical and Computational Biology in Drug Discovery

<http://mcbdd.ch>

- Syllabus
 - **Module Zero:** Introduction
 - **Module I:** What are drug targets and where to find them?
 - **Module II:** What can we do if there are no good targets?
 - **Module III:** What kind of drug should we develop?
 - **Module IV:** What efficacy and safety profiles can we expect?
 - **Module V:** For which patients will the drug work and how does it work, *really*?

Backup material

Population modelling deals with two levels of variability, which calls for mixed-effect models

- Consider a simple one-compartment model, with an intravenous bolus dose (right).
- **Two types of variability**
 - **Between-occasion variability**, e.g. the differences from one time point to the other within each patient.
 - **Between-subject variability**, e.g. the differences in clearance rate among patients
- A **mixed-effect model** (mixed=fixed+random effect model, a type of hierarchical model or *multilevel model*) is needed to model such data.
- If we assume that V_D is a constant value that is the same for all subjects, but clearance varies between subjects (for instance due to ethnicity), then V_D is a fixed-effect parameter and CL is a random-effect parameter.
- If we assume that both V_D and CL vary between subjects, then both are random-effect parameters.

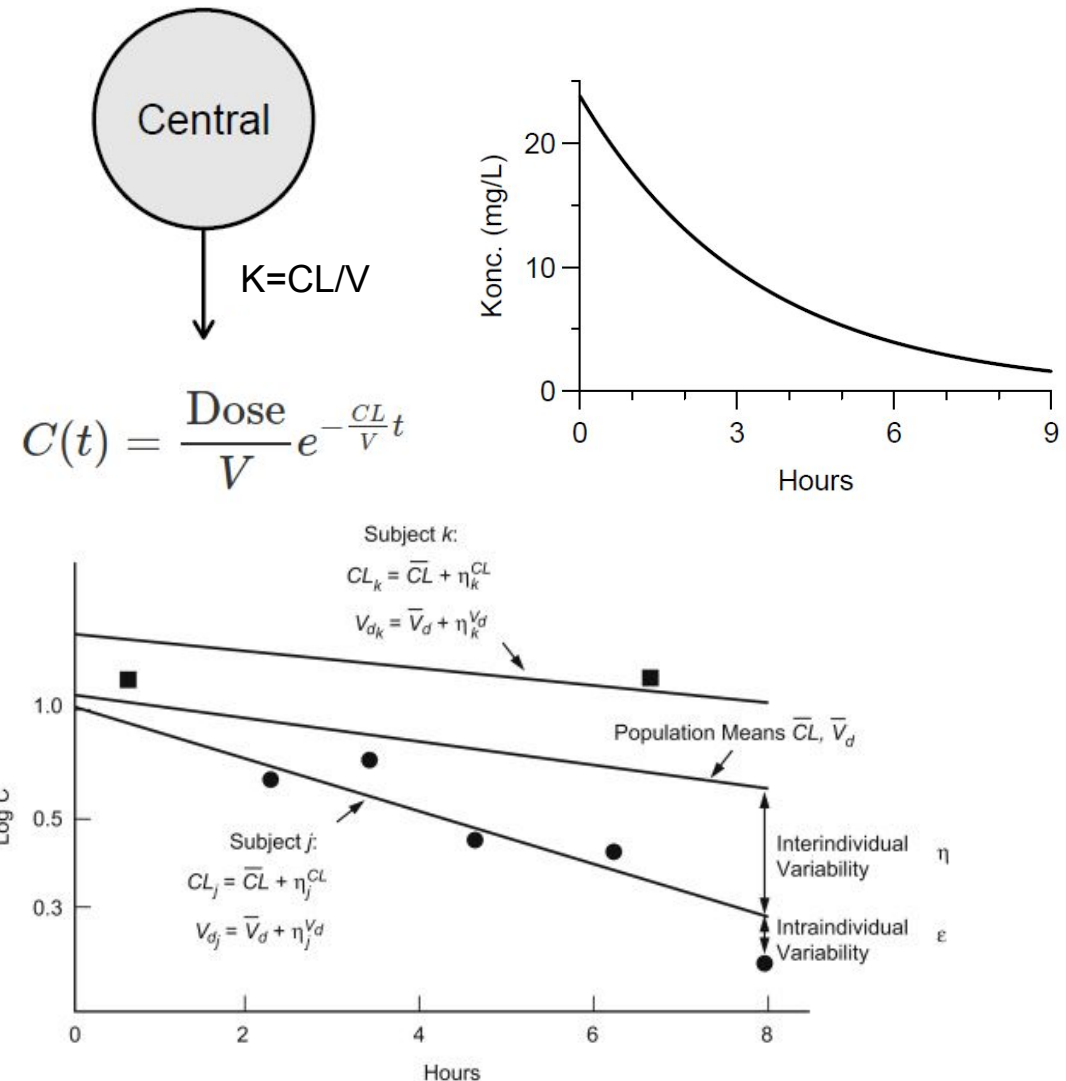

Bottom figure: Raymond Miller, in Principles of Clinical Pharmacology (Third Edition), 2012

A linear model has one level of variability

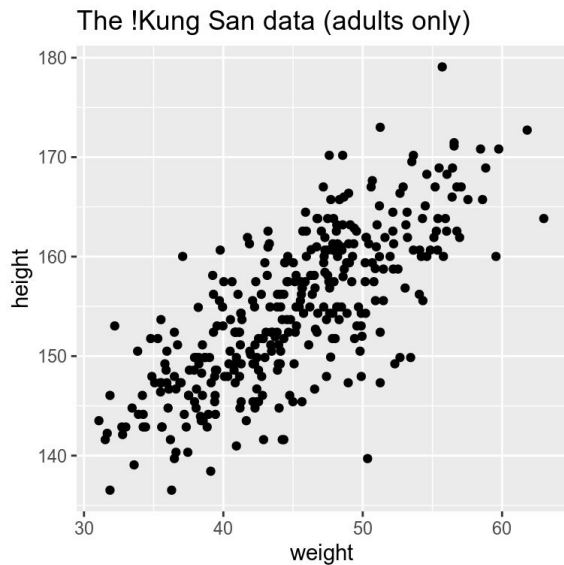

variable scaling

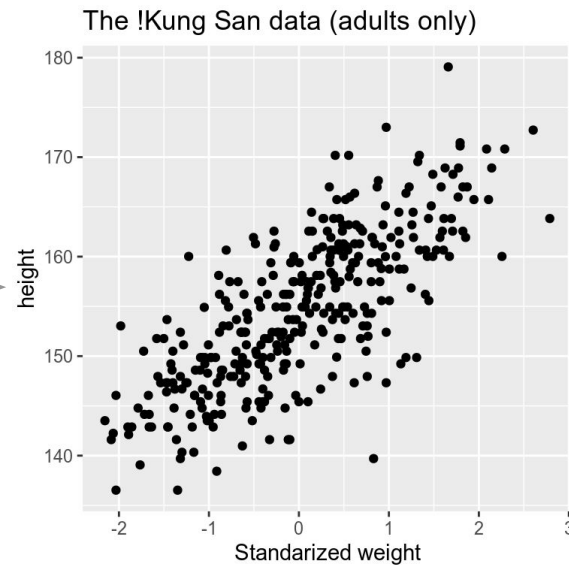

The Frequentist language

$$y_i = f(x) + \epsilon$$

$$f(x) = \alpha + \beta x$$

$$\epsilon \sim \mathcal{N}(0, \sigma)$$

The Bayesian language,
with some personal priors

$$y_i \sim \mathcal{N}(\mu_i, \sigma)$$

$$\mu = \alpha + \beta x_i$$

$$\alpha \sim \mathcal{N}(169, 20)$$

$$\sigma \sim \text{Unfoirm}(0, 50)$$

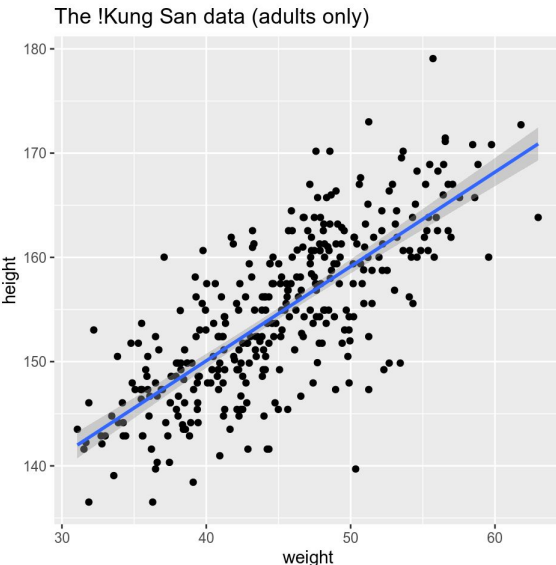

Example inspired by the *Statistical Rethinking* book by Richard McElreath

A general form of nonlinear mixed-effect models

The Bayesian language

$$y_{ij} \sim \mathcal{N}(\mu_{ij}, \Sigma_i)$$

$$\mu_{ij} = f(t_{ij}, \beta_i, d_i)$$

$$\beta_i \sim \mathcal{N}(\beta, D)$$

- y_{ij} is the j^{th} response for the i^{th} subject
- f is a scalar function nonlinear with regard to β
- β is a $k \times 1$ parameter vector, giving PK parameters such as absorption, V_D , and CL .
- t_{ij} is the j^{th} time of measurement for the i^{th} subject
- d_i is the dose of the i^{th} subject
- j ranges from 1 to n_i
- D is a $k \times k$ covariance matrix
- Σ_i is an $n_i \times n_i$ covariance matrix

The Frequentist language

$$y_{ij} = f(t_{ij}, \underline{\beta}_i, d_i) + \varepsilon_{ij}$$

$$\underline{\beta}_i \sim N(\underline{\beta}, D)$$

$$\varepsilon_{ij} \sim N(\underline{0}, R_i)$$

- y_{ij} is the j^{th} response for the i^{th} subject
- f is a scalar function nonlinear in $\underline{\beta}$
- $\underline{\beta}$ is a $k \times 1$ parameter vector
- t_{ij} is the j^{th} time for the i^{th} subject
- d_i is the i^{th} subject's dose
- j ranges from 1 to n_i
- ε_{ij} is residual error
- D is a $k \times k$ covariance matrix
- R_i is an $n_i \times n_i$ covariance matrix

In practice, maximum-likelihood estimation (MLE) based modelling fitting is performed by numerical methods including *Laplace approximation* and *Gaussian quadrature*.

One of the mostly used software is **NONMEM** (non-linear mixed effects modeling), a commercial software. Other platforms are being actively developed, for instance GTS and ITS.

NLME modelling helps understanding clinical PK-PD parameters

- Non-linear mixed-effect (NLME) models can model both drug response and disease progression.
- By incorporating covariants (biomarkers, *etc.*), NLME models can model and reveal group-specific PK/PD responses.

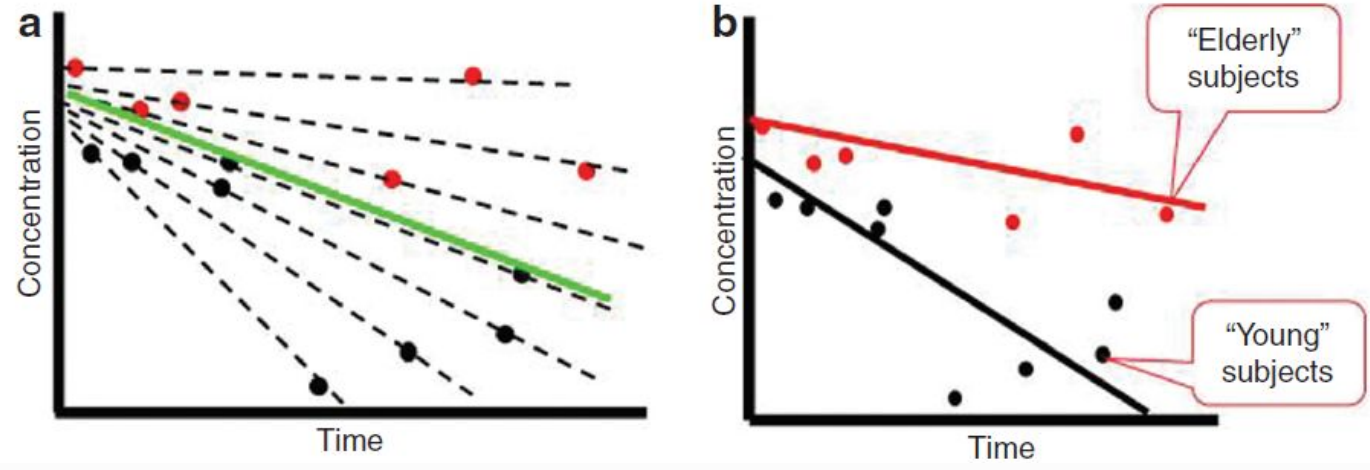

Top: Mould, D R, and R N Upton. 2012. “[Basic Concepts in Population Modeling, Simulation, and Model-Based Drug Development](#).” CPT: Pharmacometrics & Systems Pharmacology 1 (9): 1–14.

Right: Zhang, Weijiang, Dominik Heinzmann, and Joseph F. Grippo. 2017. “[Clinical Pharmacokinetics of Vemurafenib](#).” Clinical Pharmacokinetics 56 (9): 1033–43. AUC₈ and AUC₁₆₈: AUC from time zero to 8h or 168 h.

	Vemurafenib			
	240 mg bid	480 mg bid	720 mg bid	960 mg bid
Day 1	<i>n</i> = 12	<i>n</i> = 12	<i>n</i> = 12	<i>n</i> = 16
AUC ₈ (µg·h/mL)	8.3 ± 6.13 (73.9)	13.8 ± 7.72 (55.8)	21.9 ± 12.97 (59.3)	27.0 ± 18.87 (69.9)
AUC ₂₄ (µg·h/mL)	40.9 ± 23.43 (57.3)	62.4 ± 35.71 (57.2)	111.6 ± 34.22 (30.7)	130.6 ± 71.78 (55.0)
C _{max} 0–8 h (µg/mL)	1.9 ± 1.66 (85.3)	2.6 ± 1.56 (60.5)	4.4 ± 1.98 (44.6)	4.8 ± 3.34 (69.8)
<i>t</i> _{max} 0–8 h (h)	4.0 (1.92–8.00)	4.0 (1.95–5.00)	5.0 (2.00–8.08)	5.0 (2.00–8.00)
Day 15	<i>n</i> = 10	<i>n</i> = 10	<i>n</i> = 9	<i>n</i> = 11
AUC ₈ (µg·h/mL)	117.8 ± 50.52 (42.9)	233.8 ± 106.93 (45.7)	343.3 ± 151.23 (44.1)	392.2 ± 126.37 (32.2)
AUC ₁₆₈ (µg·h/mL)	920.3 ± 538.35 (58.5)	2243.5 ± 1336.15 (59.6)	3127.1 ± 1789.97 (57.2)	3530.3 ± 1811.43 (51.3)
C _{max} 0–168 h (µg/mL)	17.2 ± 7.43 (43.1)	35.4 ± 17.44 (49.2)	52.7 ± 22.40 (42.5)	61.4 ± 22.76 (37.1)
<i>t</i> _{1/2} (h)	31.5 ± 19.05 (60.4)	38.4 ± 24.18 (63.0)	34.9 ± 19.48 (55.9)	34.1 ± 19.66 (57.7)
Accumulation ratio (AUC ₈ on day 15/day 1)	24.9 ± 29.4 (118)	23.3 ± 16.0 (68.7)	18.8 ± 12.4 (66.0)	23.2 ± 16.5 (71.1)

Clinical studies and clinical trials

- A **clinical study** is research using human volunteers (*i.e.* participants), with the intention to add to medical knowledge.
- Two main types of clinical studies: **clinical trials** (also called interventional studies) and **observational studies**. In clinical trials, participants are assigned to specific **interventions** by the investigator, which is not the case in observational studies.
- **Most drug and vaccine candidates fail.**
- Only drugs undergoing successful clinical studies are approved by regulatory agencies. For instance, FDA usually requires that a drug must show statistical significance in two ‘adequate and well-controlled’ pivotal Phase III studies as a precondition of its approval.

Probability of Success² by Clinical Trial Phase and Therapeutic Area

	<i>P1 to P2</i>	<i>P2 to P3</i>	<i>P3 to Approval</i>	<i>Overall</i>
<i>Oncology</i>	57.6	32.7	35.5	3.4
<i>Metabolic/Endocrinology</i>	76.2	59.7	51.6	19.6
<i>Cardiovascular</i>	73.3	65.7	62.2	25.5
<i>Central Nervous System</i>	73.2	51.9	51.1	15.0
<i>Autoimmune/Inflammation</i>	69.8	45.7	63.7	15.1
<i>Genitourinary</i>	68.7	57.1	66.5	21.6
<i>Infectious Disease</i>	70.1	58.3	75.3	25.2
<i>Ophthalmology</i>	87.1	60.7	74.9	32.6
<i>Vaccines (Infectious Disease)</i>	76.8	58.2	85.4	33.4
<i>Overall</i>	66.4	48.6	59.0	13.8
<i>Overall (Excluding Oncology)</i>	73.0	55.7	63.6	20.9

Source: Chi Heem Wong, Kien Wei Siah, Andrew W Lo. "Estimation of clinical trial success rates and related parameters." *Biostatistics* 20(2): April 2019, Pages 273-286. Published online: 31 January 2018. DOI: 10.1093/biostatistics/kxx069

Data between 2000 and 2015 of 406,038 trials (of which 185,994 were unique) and well over 21,000 compounds were collected. The table was formatted by [ACSH](#).

Phases of clinical trials prior to approval

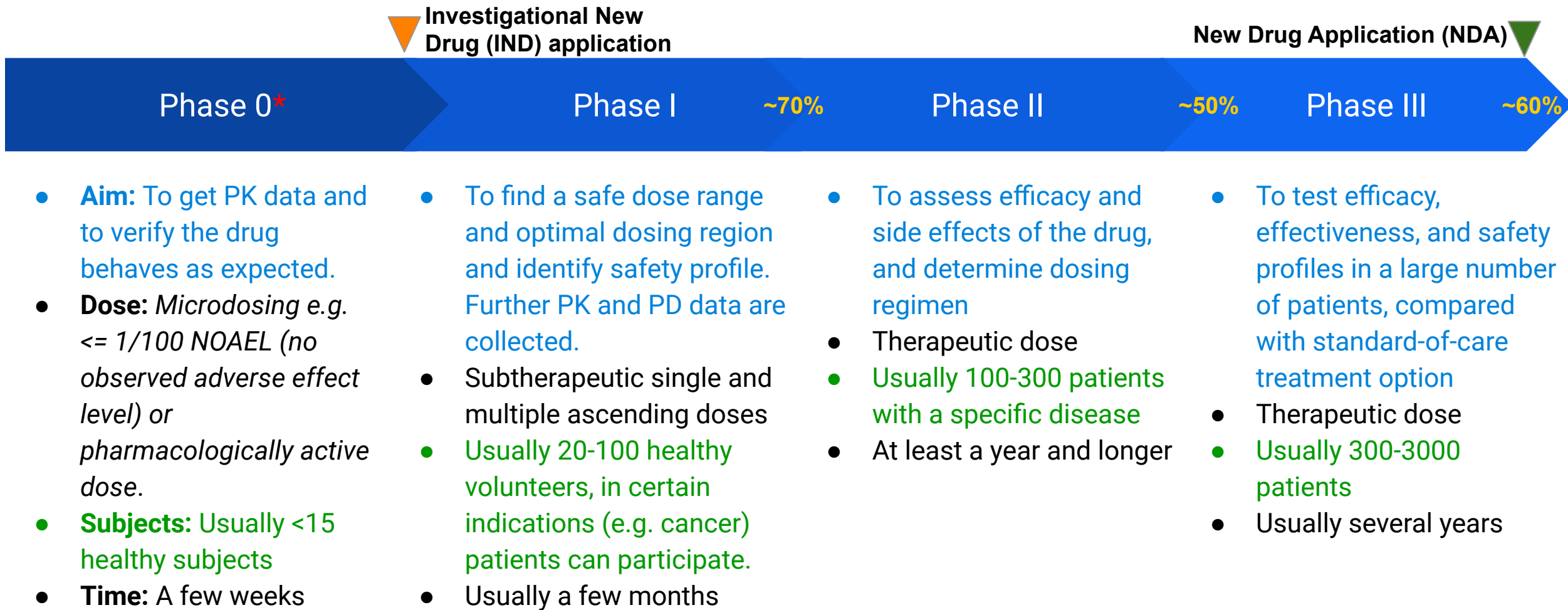

* Since early 2000. See an update-to-date review by Burt, Tal, Graeme Young, Woojin Lee, Hiroyuki Kusuhara, Oliver Langer, Malcolm Rowland, and Yuichi Sugiyama. 2020. "[Phase 0/Microdosing Approaches: Time for Mainstream Application in Drug Development?](#)" Nature Reviews Drug Discovery 19 (11): 801–18.

We use clinical endpoints, biomarkers, and surrogate endpoints to judge whether a drug works or not

- **Clinical endpoints:** direct evidence of clinical outcome, reflecting how a patient feels (e.g. relieve of anxiety and depression), functions (e.g. hospitalization), responds to pathogens (e.g. infection rate), or how long a patient survives (e.g. progression-free survival, overall survival). It can be expensive and take long to measure them.
- **Biomarkers:** objectively measured and evaluated as an indicator of normal biological, pathogenic processes or pharmacological response to a drug, which can take many forms
 - **Biochemical**, e.g. alanine aminotransferase (ALT), CD4+, cholesterol
 - **Anatomical/morphological**, e.g. tumor Size, artery diameter, and imaging results of PET, CT-Scan, MRI, *etc.*
 - **Histological**, e.g. biopsy pathology, whole blood count (WBC)
 - **Other measurements**, e.g. Blood pressure, pain relief, QT interval in electrocardiogram, *etc.*
- **Surrogate endpoints:** biomarkers supported by strong evidence so that they may substitute a clinical end point when obtaining registration, e.g. neutralising antibodies against spike proteins of the coronavirus in the plasma as a surrogate of reduced rate of infection.

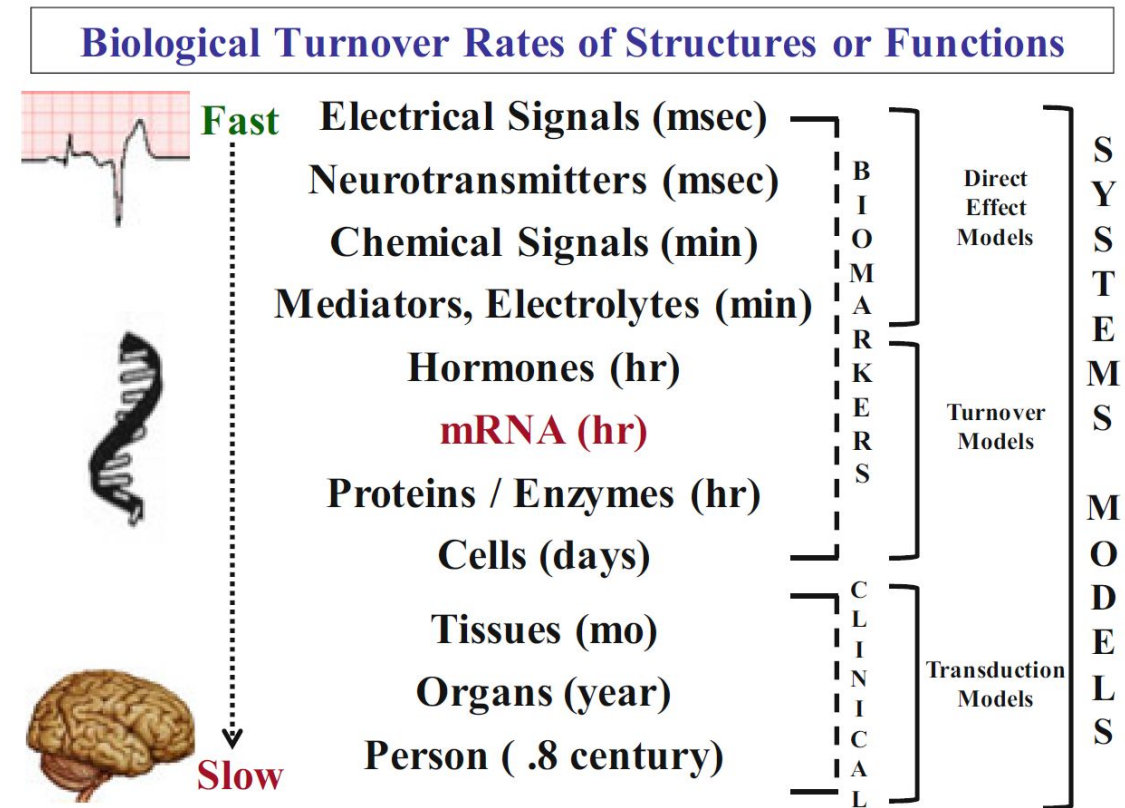

Jusko, William J. 2016. "[Foundations of Pharmacodynamic Systems Analysis.](#)" In Systems Pharmacology and Pharmacodynamics, edited by Donald E. Mager and Holly H.C. Kimko, 161–75. AAPS Advances in the Pharmaceutical Sciences Series. Cham: Springer International Publishing.